

VARIAN



vacuum technologies



For sales and service please call:

PTB Sales

Ph. (626) 334-0500

Fax (626) 334-2151

Toll Free 866-332-0500

www.ptb-sales.com

Turbo-V 1800A

Model 969-9064

Model 969-9065

Model 969-9066

MANUALE DI ISTRUZIONI

BEDIENUNGSHANDBUCH

NOTICE DE MODE D'EMPLOI

MANUAL DE INSTRUCCIONES

MANUAL DE INSTRUÇÕES

BEDRIJFSHANDLEIDING

INSTRUKSTIONSBOG

BRUKSANVISNING

INSTRUKSJON MANUAL

OHJEKÄSIKIRJA

ΟΔΗΓΙΕΣ ΧΡΗΣΕΩΣ

INSTRUCTION MANUAL

Turbo-V 1800A



VARIAN



vacuum technologies

Dear Customer,

Thank you for purchasing a VARIAN vacuum product. At VARIAN Vacuum Technologies we make every effort to ensure that you will be satisfied with the product and/or service you have purchased.

As part of our Continuous Improvement effort, we ask that you report to us any problem you may have had with the purchase or operation of our product. On the back side you find a Corrective Action Request form that you may fill out in the first part and return to us.

This form is intended to supplement normal lines of communications and to resolve problems that existing systems are not addressing in an adequate or timely manner.

Upon receipt of your Corrective Action Request we will determine the Root Cause of the problem and take the necessary actions to eliminate it. You will be contacted by one of our employees who will review the problem with you and update you, with the second part of the same form, on our actions.

Your business is very important to us. Please, take the time and let us know how we can improve.

Sincerely,

Sergio PIRAS

*Vice President and General Manager
VARIAN Vacuum Technologies*

Note: Fax or mail the Customer Request for Action (see backside page) to VARIAN Vacuum Technologies (Torino) - Quality Assurance or to your nearest VARIAN representative for onward transmission to the same address.

CUSTOMER REQUEST FOR CORRECTIVE / PREVENTIVE / IMPROVEMENT ACTION

TO : VARIAN VACUUM TECHNOLOGIES TORINO - QUALITY ASSURANCE

FAX N° : XXXX - 011 - 9979350

ADDRESS: VARIAN S.p.A. - Via F.lli Varian, 54 - 10040 Leinì (Torino) - Italy

E-MAIL : marco.marzio@varianinc.com

NAME _____	COMPANY _____	FUNCTION _____
<p>ADDRESS : _____</p> <p>TEL. N° : _____ FAX N° : _____</p> <p>E-MAIL : _____</p>		
<p>PROBLEM / SUGGESTION :</p> <p>_____</p> <p>_____</p> <p>_____</p> <p>_____</p>		
<p>REFERENCE INFORMATION (model n°, serial n°, ordering information, time to failure after installation, etc.) :</p> <p>_____</p> <p>_____</p> <p>_____</p> <p style="text-align: right;">DATE _____</p>		

<p>CORRECTIVE ACTION PLAN / ACTUATION (by VARIAN VTT)</p> <p>_____</p> <p>_____</p> <p>_____</p> <p>_____</p> <p>_____</p>	<p>LOG N° _____</p>
--	---------------------

XXXX = Code for dialing Italy from your country (es. 01139 from USA; 00139 from Japan, etc.)



ISTRUZIONI PER L'USO	1
GEBRAUCHSANLEITUNG	3
MODE D'EMPLOI	5
INSTRUCCIONES DE USO	7
INSTRUÇÕES PARA O USO	9
GEBRUIKSAANWIJZINGEN	11
BRUGSANVISNING	13
BRUKSANVISNING.....	15
BRUKERVEILEDNING	17
KÄYTTÖOHJEET	19
ΠΛΗΓΙΕΣ ΧΡΗΣΕΩΣ	21
INSTRUCTIONS FOR USE	23
TECHNICAL INFORMATION	25
DESCRIPTION OF THE TURBOPUMP	25
TECHNICAL SPECIFICATION	26
INLET SCREEN INSTALLATION	28
HEATER BAND INSTALLATION.....	28
GAS PURGE VALVE INSTALLATION	29
VENT VALVE INSTALLATION	29
VENT DEVICE INSTALLATION	29
TYPICAL LAYOUT DIAGRAM.....	30
Connection A - HIGH VACUUM FLANGE.....	30
Connection B - FORE-VACUUM PUMP.....	31
Connection C - ELECTRICAL.....	31
WATER COOLING CONNECTION	31
PUMP USED WITH CORROSIVE GASES	31
PUMP USED IN PRESENCE OF MAGNETIC FIELDS	32
ACCESSORIES	32

INFORMAZIONI GENERALI

Questa apparecchiatura è destinata ad uso professionale. L'utilizzatore deve leggere attentamente il presente manuale di istruzioni ed ogni altra informazione aggiuntiva fornita dalla Varian prima dell'utilizzo dell'apparecchiatura. La Varian si ritiene sollevata da eventuali responsabilità dovute all'inosservanza totale o parziale delle istruzioni, ad uso improprio da parte di personale non addestrato, ad interventi non autorizzati o ad uso contrario alle normative nazionali specifiche.

Le pompe della serie Turbo-V1800A sono pompe turbomolecolari per applicazioni di alto e ultra alto vuoto, capaci di pompare qualsiasi tipo di gas o di composto gassoso. Non sono adatte per il pompaggio di liquidi o di particelle solide.

L'effetto pompante è ottenuto tramite una turbina rotante ad elevata velocità (27000 giri/min. max) mossa da un motore elettrico trifase ad alto rendimento. Le pompe Turbo-V1800A sono totalmente prive di agenti contaminanti, e sono quindi adatte per applicazioni che richiedono un vuoto "pulito".

Nei paragrafi seguenti sono riportate tutte le informazioni necessarie a garantire la sicurezza dell'operatore durante l'utilizzo dell'apparecchiatura. Informazioni dettagliate sono fornite nell'appendice "Technical information".

Questo manuale utilizza le seguenti convenzioni:



PERICOLO!

I messaggi di pericolo attirano l'attenzione dell'operatore su una procedura o una pratica specifica che, se non eseguita in modo corretto, potrebbe provocare gravi lesioni personali.



ATTENZIONE!

I messaggi di attenzione sono visualizzati prima di procedure che, se non osservate, potrebbero causare danni all'apparecchiatura.

NOTA

Le note contengono informazioni importanti estrapolate dal testo.

IMMAGAZZINAMENTO

Durante il trasporto e l'immagazzinamento delle pompe non devono essere superate le seguenti condizioni ambientali:

- temperatura: da -20 °C a +70 °C
- umidità relativa: 0 - 95% (non condensante)

Se il tempo di immagazzinamento è molto lungo, avviare la pompa nel modo SOFT START (vedere il manuale del controller).

PREPARAZIONE PER L'INSTALLAZIONE

La pompa viene fornita in un imballo protettivo speciale; se si presentano segni di danni, che potrebbero essersi verificati durante il trasporto, contattare l'ufficio vendite locale.

Durante l'operazione di disimballaggio, prestare particolare attenzione a non lasciar cadere la pompa e a non sottoporla ad urti o vibrazioni.

Non disperdere l'imballo nell'ambiente. Il materiale è completamente riciclabile e risponde alla direttiva CEE 85/399 per la tutela dell'ambiente.



ATTENZIONE!

Onde evitare problemi di degassamento, non toccare con le mani nude i componenti destinati ad essere esposti al vuoto. Utilizzare sempre i guanti o altra protezione adeguata.

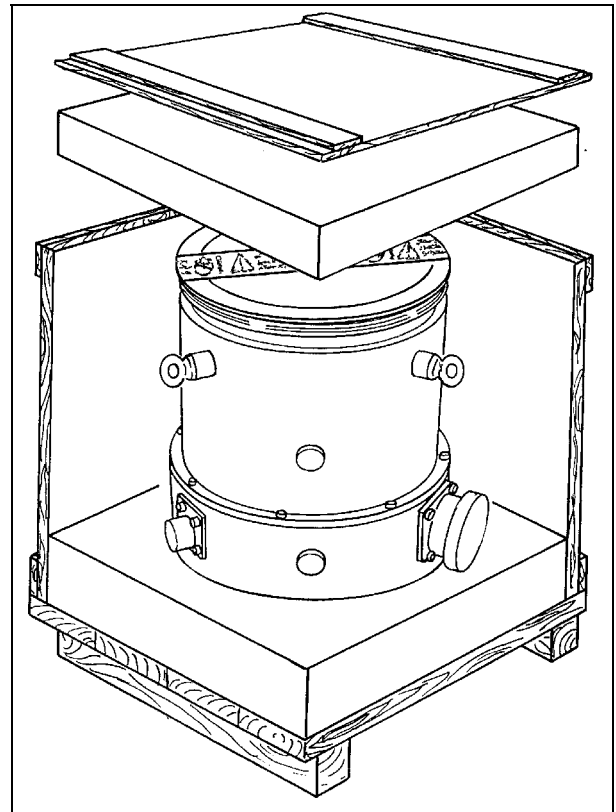

NOTA

La pompa non può essere danneggiata rimanendo semplicemente esposta all'atmosfera. Si consiglia comunque di mantenerla chiusa fino al momento dell'installazione sul sistema onde evitare eventuale inquinamento da polvere.

INSTALLAZIONE



PERICOLO!

La pompa, a causa del suo peso, deve essere maneggiata tramite appositi attrezzi di sollevamento e spostamento.

Non installare e/o utilizzare la pompa in ambienti esposti ad agenti atmosferici (pioggia, gelo, neve), polveri, gas aggressivi, in ambienti esplosivi o con elevato rischio di incendio.

Durante il funzionamento è necessario che siano rispettate le seguenti condizioni ambientali:

- pressione massima: 2 bar oltre la pressione atmosferica
- temperatura: da + 5 °C a +35 °C
- umidità relativa: 0 - 95% (non condensante).



ATTENZIONE!

Staccare l'adesivo e togliere il tappo di protezione solo al momento del collegamento della turbopompa al sistema.

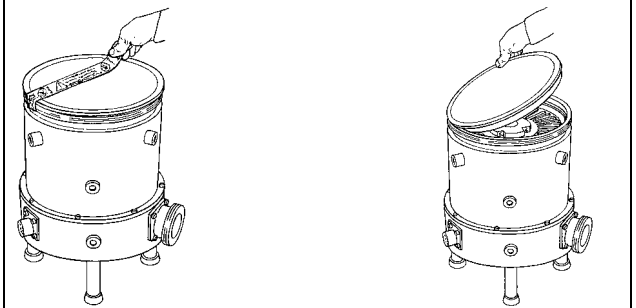

NO!

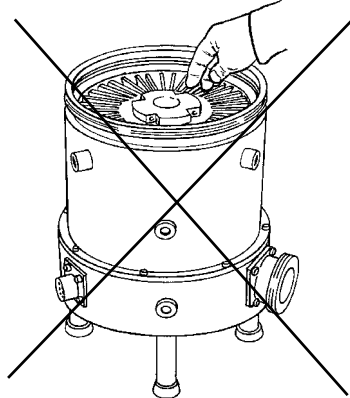

! PERICOLO!

Per evitare lesioni alla persona non inserire mai, per alcun motivo, le dita oppure oggetti nella bocca d'ingresso della turbopompa. Si consiglia l'uso della retina di protezione (opzionale). Se viene utilizzato uno smorzatore di vibrazioni oppure un soffietto metallico flessibile sulla bocca d'ingresso, fissare sempre la turbopompa alla base.

In presenza di campi elettromagnetici la pompa deve essere protetta tramite opportuni schermi. Vedere l'appendice "Technical Information" per ulteriori dettagli.

Le pompe turbomolecolari della serie Turbo-V1800A devono essere utilizzate solo con uno degli appositi controllori Varian (serie 969-9561, 969-9461) e devono essere collegate ad una pompa primaria (vedere schema in "Technical Information").

La turbopompa deve essere installata in posizione verticale, o in posizione capovolta con una inclinazione massima rispetto all'asse verticale di 10°.

La pompa può rimanere poggiata sui suoi piedi, o essere sospesa tramite la flangia di ingresso.

Fissare la turbopompa in posizione stabile collegando la flangia di ingresso della turbopompa ad una controflangia fissa capace di resistere ad una coppia di 2814 Nm attorno al proprio asse.

La turbopompa con flangia di ingresso ISO deve essere fissata alla camera da vuoto per mezzo di morsetti doppi o morsetti singoli. La seguente tabella descrive il numero di morsetti necessari e con quale coppia di serraggio stringerli.

FLANGIA	TIPO DI MORSETTO	N.	COPIA DI SERRAGGIO
ISO 250	Morsetto doppio con filettatura M10	6	22 Nm
	Morsetto singolo con filettatura M10	12	22 Nm

La turbopompa con flangia di ingresso ConFlat deve essere fissata alla camera da vuoto per mezzo dell'apposita minuteria meccanica Varian. Per ulteriori dettagli vedere l'appendice "Technical Information".

Nel caso in cui la pompa poggi sui suoi piedi, questi ultimi vanno fissati al piano di appoggio utilizzando i fori filettati M6 posti in corrispondenza dei piedi di appoggio. Questi fori sono posti su di un cerchio con diametro 285 mm (11,22 pollici).

Per l'installazione degli accessori opzionali, vedere "Technical Information".

USO

Tutte le istruzioni per il corretto funzionamento della turbopompa sono contenute nel manuale dell'unità di controllo. Leggere attentamente tale manuale prima dell'utilizzo.

Per raggiungere migliori pressioni limite è possibile riscaldare l'involucro della pompa utilizzando il riscaldatore opzionale.

Durante l'eventuale riscaldamento della camera da vuoto, la temperatura sulla flangia di ingresso non deve essere superiore a 120 °C.

Utilizzare sempre il raffreddamento ad acqua durante le operazioni di riscaldamento (vedere l'appendice "Technical information" per dettagli circa il collegamento del raffreddamento ad acqua alla pompa).

! PERICOLO!

Non toccare la turbopompa e i suoi eventuali accessori durante le operazioni di riscaldamento. L'elevata temperatura può causare lesioni alle persone.

ATTENZIONE!

Per la mandata all'aria della pompa utilizzare aria o gas inerte esente da polvere o particelle. La pressione di ingresso attraverso l'apposita porta deve essere inferiore a 2 bar (oltre la pressione atmosferica).

ATTENZIONE!

Evitare urti o bruschi spostamenti della turbopompa quando è in funzione. I cuscinetti potrebbero danneggiarsi.

ATTENZIONE!

Per il pompaggio di gas aggressivi queste pompe sono dotate di una apposita porta attraverso la quale è necessario fornire alla pompa un flusso di gas inerte (Azoto o Argon) per proteggere i cuscinetti (vedere l'appendice "Technical Information").

! PERICOLO!

Quando la pompa viene utilizzata per il pompaggio di gas tossici, infiammabili o radioattivi, seguire le appropriate procedure tipiche di ciascun gas.

Non usare la pompa in presenza di gas esplosivi.

MANUTENZIONE

Le pompe della serie Turbo-V1800A non richiedono alcuna manutenzione. Qualsiasi intervento deve essere eseguito da personale autorizzato.

! PERICOLO!

Prima di effettuare qualsiasi intervento sulla turbopompa scollegare il connettore di alimentazione, mandare all'aria la pompa aprendo l'apposita valvola, attendere fino al completo arresto del rotore ed attendere che la temperatura superficiale della pompa sia inferiore a 50°C.

In caso di guasto è possibile usufruire del servizio di riparazione Varian o del "Varian advanced exchange service", che permette di ottenere una pompa rigenerata in sostituzione di quella guasta.

NOTA

Prima di rispedire al costruttore una pompa per riparazioni o advanced exchange service, è indispensabile compilare e far pervenire al locale ufficio vendite la scheda "Sicurezza e Salute" allegata al presente manuale di istruzioni. Copia della stessa deve essere inserita nell'imballo della pompa prima della spedizione.

Qualora una pompa dovesse essere rottamata, procedere alla sua eliminazione nel rispetto delle normative nazionali specifiche.

ALLGEMEINES

Dieser Apparat ist für Fachbetriebe bestimmt. Vor Gebrauch sollte der Benutzer dieses Handbuch sowie alle weiteren mitgelieferten Zusatzdokumentationen genau lesen. Bei Nichtbeachtung -auch teilweise- der enthaltenen Hinweise, unsachgemäßem Gebrauch durch ungeschultes Personal, nicht autorisierten Eingriffen und Mißachtung der einheimischen, hier zur Geltung kommenden Bestimmungen übernimmt die Firma Varian keinerlei Haftung.

Bei den Pumpen der Serie Turbo-V1800A handelt es sich um Turbomolekularpumpen für Hoch- und Ultrahochvakuumanwendungen. Sie eignen sich für jede Art von Gas oder gashaltige Gemische, nicht jedoch zur Förderung von Flüssigkeiten oder Festpartikel.

Die Pumpwirkung wird durch eine Hochgeschwindigkeitsturbine (max. 27000 Upm) erzielt, die von einem Hochleistungs-drehstrommotor angetrieben wird. Die Turbo-V1800A-Pumpen enthalten keinerlei ungewaltschädliche Substanzen und eignen sich deshalb auch für Anwendungszwecke, die ein "sauberes" Vakuum vorschreiben. In den folgenden Abschnitten sind alle erforderlichen Informationen für die Sicherheit des Bedieners bei der Anwendung des Geräts aufgeführt. Detaillierte technische Informationen sind im Anhang "Technical Information" enthalten.

In dieser Gebrauchsanleitung werden Sicherheitshinweise folgendermaßen hervorgehoben:



GEFAHR!

Die Gefahrenhinweise lenken die Aufmerksamkeit des Bedieners auf eine spezielle Prozedur oder Praktik, die bei unkorrekter Ausführung schwere Verletzungen hervorrufen können.



ACHTUNG!

Die Warnhinweise vor bestimmten Prozeduren machen den Bediener darauf aufmerksam, daß bei Nichteinhaltung Schäden an der Anlage entstehen können.

ANMERKUNG

Die Anmerkungen enthalten wichtige Informationen, die aus dem Text hervorgehoben werden.

LAGERUNG

Beim Transport und bei der Lagerung der Pumpen müssen folgende klimatische Verhältnisse vorliegen:

- Temperatur: von -20°C bis +70°C
- Relative Luftfeuchtigkeit: 0 - 95%

Nach extrem langer Lagerung muß die Pumpe bei Inbetriebsetzung im SOFT START-Modus gestartet werden (siehe Handbuch der Steuereinheit).

VOR DER INSTALLATION

Die Pumpe wird mit einer speziellen Schutzverpackung geliefert. Eventuelle Transportschäden müssen der zuständigen örtlichen Verkaufsstelle gemeldet werden.

Beim Auspacken vorsichtig vorgehen, damit die Pumpe nicht fällt oder Stößen ausgesetzt wird.

Das Verpackungsmaterial muß korrekt entsorgt werden. Es ist vollständig recyclebar und entspricht der EG-Richtlinie 85/399 für Umweltschutz.



ACHTUNG!

Um Entgasungsprobleme zu vermeiden, dürfen die Komponenten, die in Berührung mit dem Vakuum kommen, nicht mit bloßen Händen angefaßt werden. Immer Handschuhe oder einen anderen geeigneten Schutz tragen.

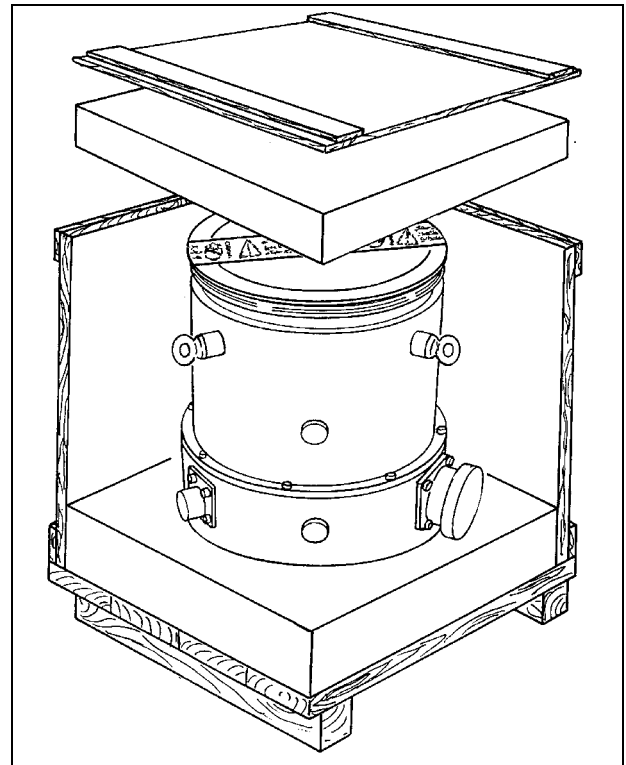

ANMERKUNG

Die Pumpe kann, wenn sie ganz einfach der Atmosphäre ausgesetzt ist, keine Schäden erleiden. Sie sollte jedoch bis zur Installation auf der Anlage geschlossen bleiben, um Staubverschmutzungen zu vermeiden.

INSTALLATION



GEFAHR!

Aufgrund ihres Gewichtes darf die Pumpe ausschließlich mittels entsprechend geeigneten Hebe- bzw. Versetzungsgeräten transportiert bzw. angehoben werden.

Die Pumpe darf nicht in Umgebungen benutzt werden, die ungeschützt vor Wetter (Regen, Frost, Schnee), Staub und aggressiven Gasen sind und in denen Explosions- und erhöhte Brandgefahr besteht.

Beim Betrieb müssen folgende Umgebungsbedingungen eingehalten werden:

- Maximaldruck: 2 Bar über dem atmosphärischen Druck
- Temperatur: von +5°C bis +35°C
- Relative Luftfeuchtigkeit: 0-95% (nicht kondensierend).



ACHTUNG!

Entfernen Sie die Klebefolie und den Schutzdeckel erst beim Anschluß der Turbopumpe an die Anlage.

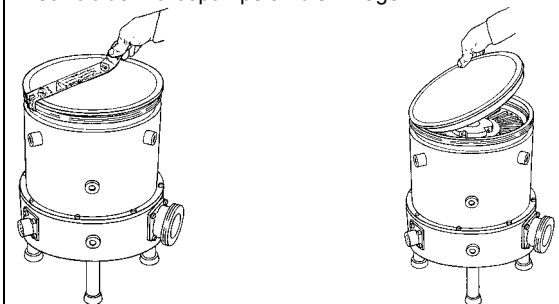

NEIN!

GEFAHR!

Um Verletzungen auszuschließen, darf auf keinen Fall in die Einlaßöffnung der Turbopumpe gegriffen oder irgendwelche Gegenstände eingeführt werden. Es wird empfohlen, ein Schutzgitter zu installieren (Sonderzubehör). Bei Installation eines Erschütterungsdämpfers oder eines flexiblen Metallbalges auf der Einlaßöffnung muß die Turbopumpe immer am Unterteil fest installiert sein.

Sind Magnetfelder vorhanden, müssen die Pumpen über Einsatz eines entsprechend geeigneten Schutzschirms geschützt werden.

Die Turbomolekularpumpen der Baureihe Turbo-V1800A dürfen ausschließlich mit einer der Varian-Spezialsteuerungen betrieben werden (Baureihen 969-9561, 969-9461) und müssen an eine Primärpumpe angeschlossen werden (siehe Schema "Technical Information").

Die Turbopumpen müssen in vertikaler oder aber in invertierter Position installiert werden; die maximal zulässige Neigung zur vertikalen Achse beträgt dabei 10°.

Die Pumpen können ebenso auf den eigenen Standbeinen stehend oder durch Befestigung am Eingangsflansch in angehobener Position betrieben werden.

Befestigen Sie die Turbopumpe in einer stabilen Position, indem Sie den Eingangsflansch der Pumpe an einen festen Gegenflansch anschließen, der um die eigene Achse einem Drehmoment von 2814 Nm standhalten muß.

Turbopumpen mit ISO-Eingangsflansch müssen mittels doppelten oder einfachen Klemmschellen an die Vakuumkammer angeschlossen werden. In der nachstehenden Tabelle sind die Anzahl der jeweils erforderlichen Klemmschellen sowie der jeweilige Anzugsmoment angegeben.

FLANSCH	SCELLENART	ANZAHL	ANZUGSMOMENT
ISO 250	Doppelklemme mit NM10-Gewinde	6	22 Nm
	Einzelklemme mit NM10-Gewinde	12	22 Nm

Turbopumpen mit ConFlat-Eingangsflansch müssen mit dem speziellen Varian-Befestigungsmaterial an die Vakuumkammer angeschlossen werden. Weitere Hinweise siehe Anhang "Technical Information".

Sollte die Pumpe auf ihren eigenen Standfüßen stehend betrieben werden, so müssen diese mittels der an den Füßen befindlichen M6-Gewindebohrungen befestigt werden. Diese Bohrungen sind in einem Kreis mit einem Durchmesser von 285 mm (11,2 Zoll) angebracht.

Installation Sonderzubehör: siehe Anhang "Technical Information".

ANWENDUNG

Sämtliche Hinweise für den korrekten Betrieb der Turbopumpe sind im Handbuch der Steuereinheit enthalten.

Dieses Handbuch sollte vor der Inbetriebnahme genau gelesen werden. Um einen optimalen Enddruck zu erhalten, kann das Pumpengehäuse mit einer Heizmanschette (Optional) ausgeheizt werden.

Damit die Flanschgrenztemperatur der Turbopumpe 120°C nicht überschreitet, sollte immer bei ausheizbaren Vakuumsystemen die TP mit Wasserkühlung arbeiten (genauere Angaben zum Anschluß des Kühlwasserkreises an die Pumpe siehe Anhang "Technical Information").

GEFAHR!

Während des Ausheizens dürfen weder die Pumpe noch eventuelle heiße Anschlußteile berührt werden, denn es besteht Verbrennungsgefahr.

ACHTUNG!

Für die Belüftung der Pumpe trockene staub- und partikelfreie Luft, oder Edelgase verwenden. Der Eingangsdruck am Belüftungsanschluß muß kleiner als 2 bar über dem atmosphärischen Druck sein.

ACHTUNG!

Während des Betriebs darf die Pumpe weder Stößen noch ruckartigen Bewegungen ausgesetzt werden, da die Lager beschädigt werden können.

ACHTUNG!

Zum Pumpen von aggressiven Gasen sind die Pumpen mit einer Öffnungsklappe ausgestattet, über die zum Schutz der Lager ausschließlich Edelgas (Stickstoff oder Argon) zugeführt werden darf (siehe Anhang "Technical Information").

GEFAHR!

Wenn die Pumpe zur Förderung von giftigen, leicht entflammaren oder radioaktiven Gasen benutzt wird, müssen die für das jeweilige Gas vorgeschriebenen Vorgänge und Maßnahmen befolgt werden. Benutzen Sie die Pumpe niemals in Präsenz von explosiven Gasen.

WARTUNG

Die Pumpen der Baureihe Turbo-V1800A sind wartungsfrei. Eventuelle Eingriffe dürfen nur von autorisierten Fachkräften vorgenommen werden.

GEFAHR!

Vor jedem Eingriff an der Turbopumpe den Netzstecker ziehen, die Pumpe über Öffnung des entsprechenden Ventils belüften, warten bis der Rotor vollkommen stillsteht und die Temperatur am Pumpengehäuse unter 50°C abgesunken ist.

Bei einem Defekt kann der Varian Service oder der " advanced exchange service" in Anspruch genommen werden.

ANMERKUNG

Vor dem Versand einer defekten Pumpe an die Fa. Varian muß das Formular "Sicherheit und Gesundheit", das diesem Handbuch beiliegt, ausgefüllt an Varian geschickt und bestätigt werden. Eine Kopie muß den Frachtpapieren beigelegt werden.

Eine eventuelle Verschrottung muß unter Einhaltung der einschlägigen landesüblichen Vorschriften erfolgen.

INDICATIONS GENERALES

Cet appareillage a été conçu en vue d'une utilisation professionnelle. Il est conseillé à l'utilisateur de lire attentivement cette notice d'instructions ainsi que toute autre indication supplémentaire fournie par Varian, avant d'utiliser l'appareil. Varian décline par conséquent toute responsabilité en cas d'inobservation totale ou partielle des instructions données, d'utilisation incorrecte de la part d'un personnel non formé, d'opérations non autorisées ou d'un emploi contraire aux réglementations nationales spécifiques.

Les pompes de la série Turbo-1800A sont des pompes turbomoléculaires conçues pour des applications de vide poussé et ultrapoussé, capables de pomper n'importe quel type de gaz ou de composé gazeux. Elles ne sont pas indiquées pour le pompage de liquides ou de particules solides.

L'effet de pompage est obtenu grâce à une turbine tournant à vitesse élevée (27000 tr/min maxi), mue par un moteur électrique triphasé à haut rendement. Les pompes Turbo-V1800A sont totalement dépourvues d'agents polluants et sont par conséquent indiquées pour les applications exigeant un vide "propre".

Les paragraphes suivants donnent toutes les indications nécessaires à garantir la sécurité de l'opérateur pendant l'utilisation de l'appareillage. Des renseignements plus détaillés se trouvent dans l'appendice "Technical Information".

Cette notice utilise les signes conventionnels suivants:



DANGER!

Les messages de danger attirent l'attention de l'opérateur sur une procédure ou une manoeuvre spéciale qui, si elle n'est pas effectuée correctement, risque de provoquer de graves lésions.



ATTENTION!

Les messages d'attention apparaissent avant certaines procédures qui, si elles ne sont pas observées, pourraient endommager sérieusement l'appareillage.

NOTE

Les notes contiennent des renseignements importants, isolés du texte.

EMMAGASINAGE

Pendant le transport et l'emmagasinage des pompes, il faudra veiller à respecter les conditions environnementales suivantes:

- température: de - 20°C - à + 70°C
- humidité relative 0 - 95 % (non condensante)

Si le temps d'emmagasinage est très long, mettre la pompe en marche en mode SOFT START (voir la notice du contrôleur).

PREPARATION POUR L'INSTALLATION

La pompe est fournie dans un emballage de protection spécial; si l'on constate des marques de dommages pouvant s'être produits pendant le transport, contacter aussitôt le bureau de vente local. Pendant l'opération d'ouverture de l'emballage, veiller tout particulièrement à ne pas laisser tomber la pompe et à ne lui faire subir aucun choc ni aucune vibration.

Ne pas disperser l'emballage dans la nature. Le matériel est entièrement recyclable et il est conforme à la directive CEE 85/399 en matière de protection de l'environnement.



ATTENTION!

En vue d'éviter tous problèmes de dégazage, ne pas toucher, les mains nues, les éléments devant être exposés au vide. Mettre toujours des gants ou toute autre protection appropriée.

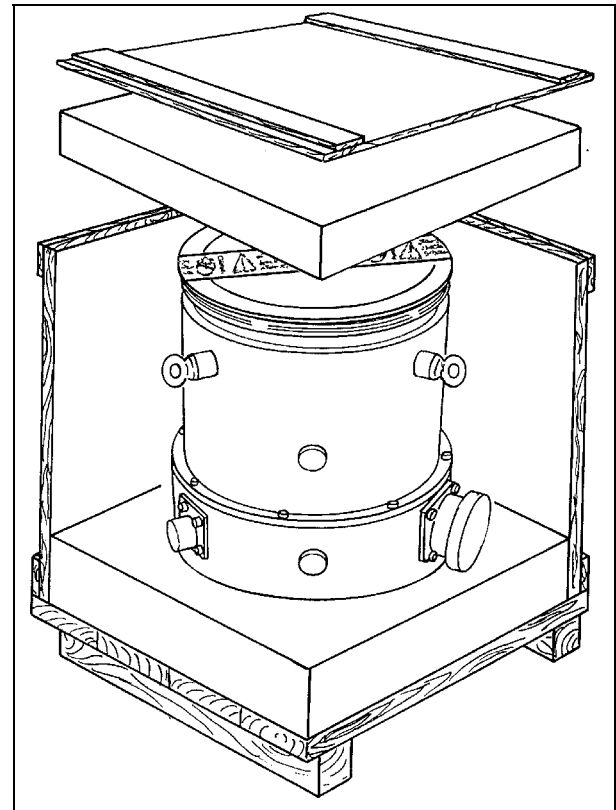

NOTE

La pompe ne peut être endommagée en restant simplement exposée à l'atmosphère. Il est de toute façon conseillé de la garder enfermée jusqu'au moment de l'installation, afin d'éviter toute pollution due à la poussière.

INSTALLATION



DANGER!

En vertu de son poids, la pompe doit être manipulée à l'aide d'outils de levage et de déplacement appropriés.

Ne pas installer et/ou utiliser la pompe dans des milieux exposés à des agents atmosphériques (pluie, gel, neige), à des poussières, à des gaz de combat ainsi que dans des milieux explosifs ou à risque élevé d'incendie. Pendant le fonctionnement, il est nécessaire de respecter les conditions environnementales suivantes:

- pression maxi: 2 bar au-delà de la pression atmosphérique
- température: de +5°C° à +35°C
- humidité relative: 0 - 95% (non condensante)



ATTENTION!

N'enlever l'adhésif, puis le couvercle qu'au moment de la connexion de la turbopompe au système.

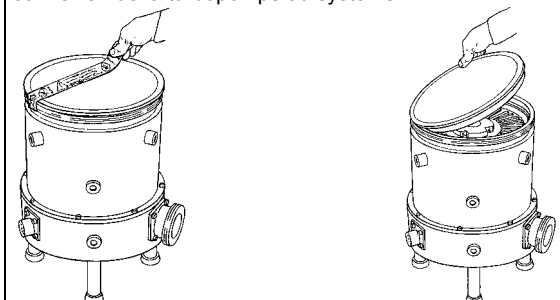

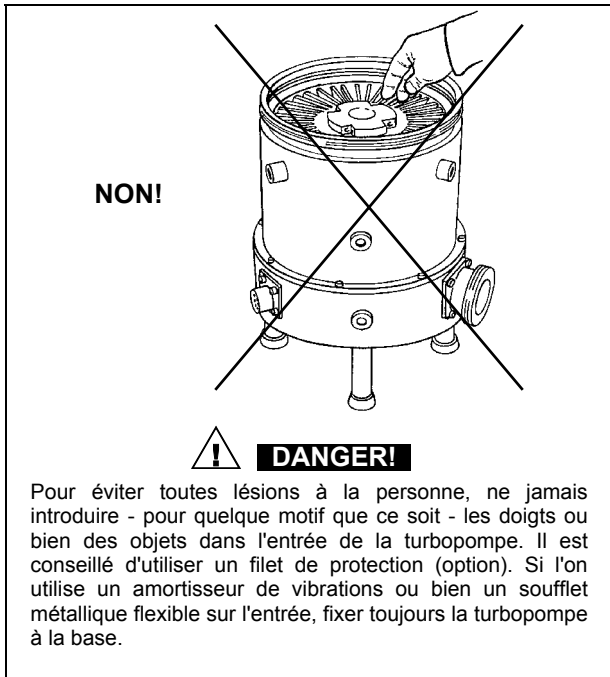

En présence de champs magnétiques, la pompe doit être protégée par des écrans appropriés. Pour tous autres détails, se reporter à l'appendice "Technical Information".

Les pompes turbomoléculaires de la série Turbo-V1800A ne doivent être utilisées qu'avec l'un des contrôleurs spéciaux Varian (série 969-9561, 969-9461) et doivent être connectées à une pompe primaire (Cf. schéma dans "Technical Information"). La turbopompe devra être installée en position verticale ou en position retournée avec une inclinaison maximum de 10° par rapport à l'axe vertical.

La pompe peut être mise en appui sur ses pieds ou suspendue à l'aide de la bride d'entrée. Fixer la turbopompe dans une position stable en reliant la bride d'entrée à une contre-bride fixe pouvant supporter un couple de 2814 Nm autour de son axe.

La turbopompe à bride d'entrée ISO doit être fixée à la chambre à vide à l'aide de colliers doubles ou simples. Le tableau suivant indique le nombre de colliers nécessaires et le couple de serrage prescrit.

BRIDE	TYPE DE COLLIER	NBRE	COUPLE DE SERRAGE
ISO 250	Collier double à filetage M10	6	22 Nm
	Collier simple à filetage M10	12	22 Nm

La turbopompe à bride d'entrée ConFiat doit être fixée à la chambre à vide à l'aide des éléments mécaniques Varian prévus à cet effet. Pour tout autre détail, se reporter à l'appendice "Technical Information".

Au cas où la pompe repose sur ses pieds, ceux-ci doivent être fixés à la base de la pompe à l'aide des orifices filetés M6 positionnés en correspondance des pieds. Ces orifices sont placés sur un cercles de 285 mm de diamètre (11,22 pouces). Pour l'installation des accessoires en option, consulter "Technical Information".

UTILISATION

Toutes les instructions pour le fonctionnement correct de la turbopompe sont contenues dans la notice de l'unité de contrôle.

Il est conseillé de lire attentivement cette notice avant d'utiliser la pompe. Pour atteindre de meilleures pressions limite, il est possible de chauffer le carter de la pompe à l'aide du

réchauffeur optionnel. Pendant le chauffage éventuel de la chambre à vide, la température de la bride d'entrée ne doit pas dépasser 120°C. Utiliser toujours le refroidissement par eau pendant les opérations de chauffage.

Utiliser toujours le refroidissement par eau pendant les opérations de chauffage. Pour plus de détails sur le branchement du refroidissement à l'eau de la pompe, consulter l'appendice "Technical Information".

! DANGER!

Eviter de toucher la turbopompe ainsi que ses accessoires éventuels pendant les opérations de chauffage. La température élevée peut causer des lésions aux personnes.

ATTENTION!

Pour le refoulement de l'air de la pompe, utiliser de l'air ou du gaz inerte exempt de poussière ou de particules. La pression d'entrée à travers la porte prévue à cet effet doit être inférieure à 2 bar au-delà de la pression atmosphérique.

ATTENTION!

Eviter tous chocs ou déplacements brusques de la turbopompe lorsqu'elle est en marche. Cela pourrait endommager les coussinets.

ATTENTION!

Pour le pompage de gaz de combat, ces pompes sont dotées d'une porte spéciale à travers laquelle il est nécessaire de fournir à la pompe un flux de gaz inerte (azote ou argon) pour protéger les coussinets (voir l'appendice "Technical Information").

! DANGER!

Lorsque la pompe est utilisée pour le pompage de gaz toxiques, inflammables ou radioactifs, suivre les procédures typiques de chaque gaz.

Ne pas utiliser la pompe en présence de gaz explosifs.

ENTRETIEN

Les pompes de la série Turbo-V1800A ne requièrent aucun entretien particulier. Toute intervention doit être effectuée par du personnel agréé.

! DANGER!

Avant de procéder à toute opération sur la turbopompe, débrancher le connecteur, refouler l'air de la pompe en ouvrant la soupape prévue à cet effet et attendre jusqu'à l'arrêt complet du rotor et jusqu'à ce que la température superficielle de la pompe soit inférieure à 50°C.

En cas de panne, il est possible de s'adresser au service réparations Varian ou bien au "Varian advanced exchange service" qui permet d'obtenir une pompe régénérée à la place de la pompe détraquée.

NOTE

Avant de renvoyer au constructeur une pompe pour des réparations ou un "advanced exchange service", remplir et faire parvenir au bureau local Varian la fiche "Sécurité et Santé" annexée à la présente notice d'instructions. Une copie de cette fiche devra être mise dans l'emballage de la pompe avant l'expédition.

En cas de mise au rebut de la pompe, procéder à son élimination conformément aux réglementations nationales en la matière.

INFORMACION GENERAL

Este equipo se ha concebido para un uso profesional. El usuario deberá leer atentamente el presente manual de instrucciones y cualquier otra información suplementaria facilitada por Varian antes de utilizar el equipo. Varian se considera libre de cualquier responsabilidad debida al incumplimiento total o parcial de las instrucciones, al uso poco apropiado por parte de personal sin adiestrar, a las intervenciones no autorizadas o al uso que no cumpla con las normas nacionales específicas.

Las bombas de la serie Turbo-1800A son bombas turbomoleculares para aplicaciones de vacío alto y ultra alto que pueden bombear cualquier tipo de gas o de compuesto gaseoso. No son apropiadas para bombear líquidos o partículas sólidas.

El efecto de bombeo se consigue mediante una turbina rotativa de alta velocidad (27000 r.p.m./min. máx) movida por un motor trifásico de gran rendimiento. Las bombas Turbo-V1800A no llevan ningún tipo de agentes contaminantes y por lo tanto son aptas para aplicaciones que requieren un vacío "limpio".

Los apartados siguientes contienen toda la información necesaria para garantizar la seguridad necesaria del operador al utilizar el aparato. Información más detallada se puede encontrar en el anexo "Technical Information".

Este manual utiliza los símbolos convencionales siguientes:



¡PELIGRO!

Los mensajes de peligro atraen la atención del operador sobre un procedimiento o una operación específica que, al no realizarse correctamente, podría provocar graves lesiones personales.



¡ATENCIÓN!

Los mensajes de atención se visualizan antes de procedimientos que, al no respetarse, podrían provocar daños al equipo.

NOTA

Las notas contienen información importante extraída del texto.

ALMACENAMIENTO

Durante el transporte y el almacenamiento de las bombas se deberá cumplir con las condiciones ambientales siguientes:

- temperatura: de -20°C a +70°C
- humedad relativa: 0 - 95% (no condensadora)

Si el periodo de almacenamiento es muy largo, poner en marcha la bomba en modalidad SOFT START (véase el manual de la unidad de control).

PREPARACION PARA LA INSTALACION

La bomba se suministra en un embalaje de protección dimensional; si se observan señales de daños, que podrían haberse producido durante el transporte, ponerse en contacto con la oficina de venta más cercana.

Durante la operación de desembalaje, prestar una atención especial a no dejar caer la bomba ni someterla a golpes.

No dispersar el embalaje en el medio ambiente. El material es totalmente reciclable y se ajusta a la directiva CEE/399 para la preservación del medio ambiente.



¡ATENCIÓN!

Para evitar la degasificación, no tocar con las manos sin guantes los componentes destinados a someterse al vacío. Utilizar siempre los guantes u otra protección apropiada.

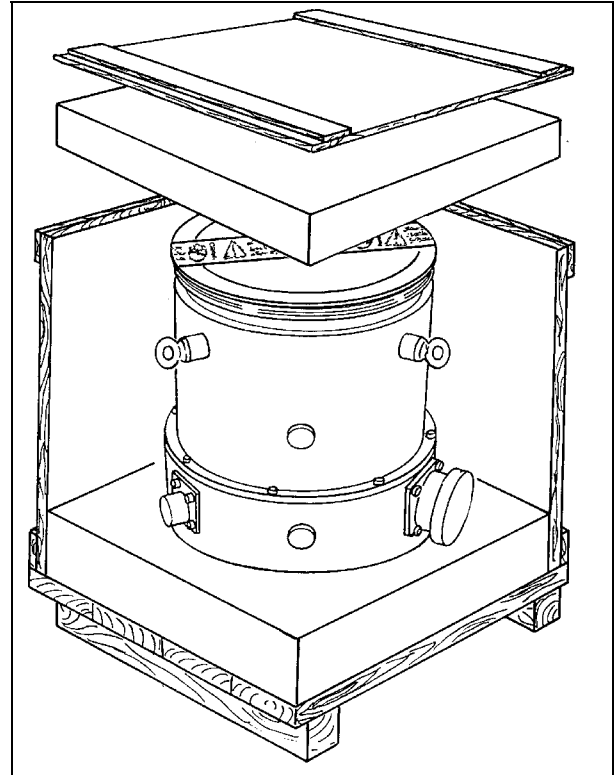

NOTA

La bomba no se puede dañar sólo por quedar expuesta a la atmósfera. De todas formas, se aconseja mantenerla cerrada hasta el momento de la instalación en el sistema para evitar una posible contaminación debida al polvo.

INSTALACION



¡PELIGRO!

A causa de su peso, la bomba ha de manejarse utilizando las herramientas específicas de levantamiento y desplazamiento.

No instalar ni utilizar la bomba en ambientes expuestos a agentes atmosféricos (lluvia, hielo, nieve), polvos, gases agresivos, en ambientes explosivos o con alto riesgo de incendio.

Durante el funcionamiento es preciso que se respeten las condiciones ambientales siguientes:

- presión máxima: 2 bar por encima de la presión atmosférica
- temperatura: de +5°C a +35°C
- humedad relativa: 0 - 95% (no condensadora)



¡ATENCIÓN!

Eliminar el adhesivo y quitar el tapón de protección sólo en el momento en que se conecte la turbobomba al sistema.

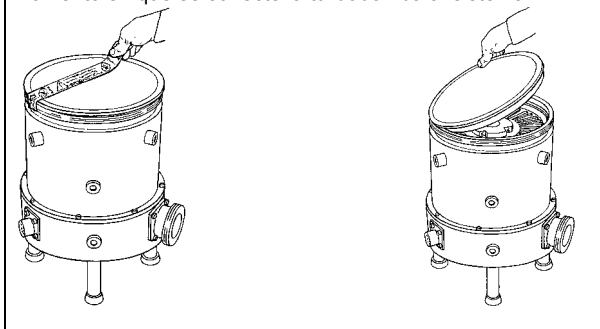



Cuando hay campos electromagnéticos la bomba ha de protegerse mediante pantallas oportunas. Véase el apéndice "Technical Information" para más detalles.

Las bombas turbomoleculares de la serie Turbo-V1800A han de utilizarse exclusivamente con uno de los controladores Varian (serie 969-9561, 969-9461) y se conectarán a una bomba primaria (véase esquema en "Technical Information").

La turbobomba se instalará en posición vertical o en posición invertida con una inclinación máxima respecto al eje vertical de 10°.

La bomba puede permanecer apoyada sobre sus patas o colgarse mediante la brida de entrada.

Fijar la turbobomba en posición estable uniendo la brida de entrada de la turbobomba con una contrabrida fija capaz de resistir a un par de 2814 Nm alrededor de su eje.

La turbobomba con brida de entrada ISO ha de ir fijada a la cámara de vacío mediante mordazas dobles o mordazas individuales. La tabla siguiente describe el número de mordazas necesarias y el par de apriete al que han de apretarse.

BRIDA	TIPO DE MORDAZA	N.	PAR DE APRIETE
ISO 250	Mordaza doble con rosca M10	6	22 Nm
	Mordaza individual con rosca M10	12	22 Nm

La turbobomba con brida de entrada ConFiat se fijará a la cámara de vacío mediante los accesorios mecánicos Varian. Para más detalles véase el anexo "Technical Information".

Si la bomba se apoya sobre sus patas, éstas se fijarán a la superficie de apoyo utilizando los orificios roscados M6 situados a la altura de las patas de apoyo. Estos orificios están colocados sobre un círculo con un diámetro de 285 mm (11,22 pulgadas).

Para instalar los accesorios opcionales, véase "Technical Information".

UTILIZACION

Todas las instrucciones para el funcionamiento correcto de la turbobomba se encuentran en el manual de la unidad de control.

Leer atentamente dicho manual antes de utilizarla.

Para obtener mejores presiones límite, se puede calentar la envoltura de la bomba utilizando el calentador opcional. Durante el posible calentamiento de la cámara de vacío, la

temperatura de la brida de entrada no deberá superar 120°C. Utilizar siempre la refrigeración por agua durante las operaciones de calentamiento.

Utilizar siempre la refrigeración por agua durante las operaciones de calentamiento (véase el anexo "Technical Information" para detalles sobre la conexión de la refrigeración por agua a la bomba).



No tocar la turbobomba y sus posibles accesorios durante las operaciones de calentamiento. La alta temperatura puede provocar lesiones a las personas.



Para el envío de aire de la bomba utilizar aire o gas inerte sin polvo o partículas. La presión de entrada a través de la puerta apropiada deberá ser inferior a 2 bar por encima de la presión atmosférica.



Evitar los golpes o desplazamientos rápidos de la turbobomba cuando está en marcha. Los rodamientos se podrían dañar.



Para bombear gases agresivos estas bombas están dotadas de una puerta específica mediante la cual es necesario suministrar a la bomba un caudal de gas inerte (Nitrógeno o Argón) para proteger los rodamientos (véase el apéndice "Technical Information").



Cuando la bomba se utiliza para bombear gases tóxicos, inflamables o radioactivos, seguir los procedimientos apropiados típicos de cada gas.

No usar la bomba cuando haya gases explosivos.

MANTENIMIENTO

Las bombas de la serie Turbo-V1800A no necesitan ningún tipo de mantenimiento. Cualquier operación tendrá que ser realizada por personal autorizado.



Antes de realizar cualquier intervención en la turbobomba, desempalmar el conector de alimentación, enviar aire a la bomba abriendo la válvula apropiada y esperar hasta que el rotor se pare completamente y esperar a que la bomba esté por debajo de 50 °C.

En caso de avería se podrá utilizar el servicio de reparación Varian o el "Varian advanced exchange service", que permite obtener una bomba regenerada para sustituir la averiada.

NOTA

Antes de enviar al fabricante una bomba para su reparación o "advanced exchange service", es imprescindible cumplimentar y remitir a la oficina de Ventas más cercana la ficha de "Seguridad y Salud" adjunta al presente manual de instrucciones. Una copia de la misma se deberá introducir en el embalaje de la bomba antes de enviarla.

En caso de que la bomba se tenga que desgazar, efectuar su eliminación respetando las normas nacionales específicas.

INFORMAÇÕES GERAIS

Esta aparelhagem destina-se ao uso profissional. O utilizador deve ler atentamente o presente manual de instruções e qualquer outra informação adicional fornecida pela Varian antes de usar a aparelhagem. A Varian não se responsabiliza pela eventual inobservância total ou parcial das instruções, pelo uso indevido por parte de pessoas não treinadas, por operações não autorizadas ou pelo uso contrário às normas nacionais específicas.

As bombas da série Turbo-V1800A são bombas turbomoleculares para aplicações de alto e ultra-alto vácuo, capazes de bombear qualquer tipo de gás ou de composto gasoso. Não são adequadas para bombear líquidos ou partículas sólidas.

O efeito da bomba é obtido através de uma turbina rotativa de alta velocidade (27.000 r.p.m. máx.) movida por um motor eléctrico trifásico de alto rendimento. As bombas Turbo-V1800A são totalmente sem agentes contaminadores e, portanto, são adequadas para aplicações que requerem um vácuo "limpo".

Nos parágrafos seguintes estão descritas todas as informações necessárias para garantir a segurança do técnico durante o uso da aparelhagem. Informações detalhadas são fornecidas no apêndice "Technical Information".

Este manual utiliza as seguintes convenções:



PERIGO!

As mensagens de perigo chamam a atenção do técnico para um procedimento ou uma prática específica que, se não efectuada correctamente, poderia provocar graves lesões pessoais.



ATENÇÃO!

As mensagens de atenção são visualizadas antes de procedimentos que, se não observados, poderiam causar danos à aparelhagem.

OBS

As obs. contêm informações importantes destacadas do texto.

ARMAZENAGEM

Durante o transporte e a armazenagem das bombas não devem ser superadas as seguintes condições ambientais:

- temperatura: de -20°C a +70°C
- humidade relativa: 0 - 95% (não condensante)

Se o tempo de armazenagem for muito longo, accionar a bomba em SOFT START (ver manual da unidade de controlo).

PREPARAÇÃO PARA A INSTALAÇÃO

A bomba é fornecida numa embalagem protectora especial; se apresentarem sinais de danos, que poderiam verificar-se durante o transporte, entrar em contacto com o escritório de vendas local.

Durante a retirada da embalagem, tomar muito cuidado para não deixar cair a bomba e não submetê-la a colisões ou vibrações.

Não depositar a embalagem no meio ambiente. O material é completamente reciclável e responde às normas CEE 85/399 para a protecção do meio ambiente.



ATENÇÃO!

Para evitar problemas de perdas de gás, não tocar com as mãos os componentes destinados à exposição do vácuo. Utilizar sempre luvas ou outra protecção adequada.

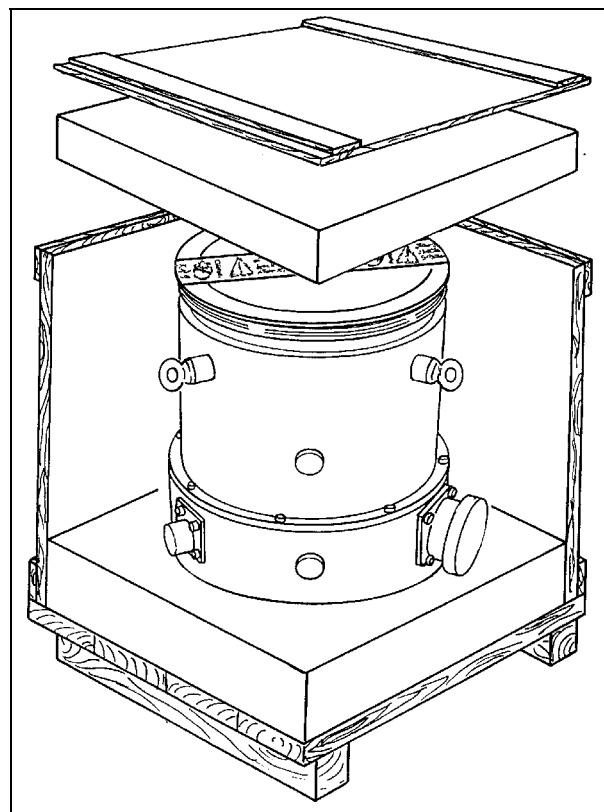

OBS

A bomba não pode ser danificada permanecendo simplesmente exposta à atmosfera. Aconselha-se, no entanto, mantê-la fechada até o momento da instalação no sistema para evitar que se suje com poeiras.

INSTALAÇÃO



PERIGO!

A bomba, devido ao seu peso, deve ser manuseada utilizando os equipamentos apropriados para o levantamento e a movimentação.

Não instalar e/ou usar a bomba em ambientes expostos a agentes atmosféricos (chuva, gelo, neve), poeiras, gases agressivos, em ambientes com possibilidade de explosão ou com elevado risco de incêndio.

Durante o funcionamento é necessário que sejam respeitadas as seguintes condições ambientais:

- pressão máxima: 2 bar além da pressão atmosférica
- temperatura: de + 5°C a + 35°C
- humidade relativa: 0 - 95% (não condensante).



ATENÇÃO!

Remover o adesivo e retirar o tampão de protecção só no momento da ligação da turbobomba ao sistema.

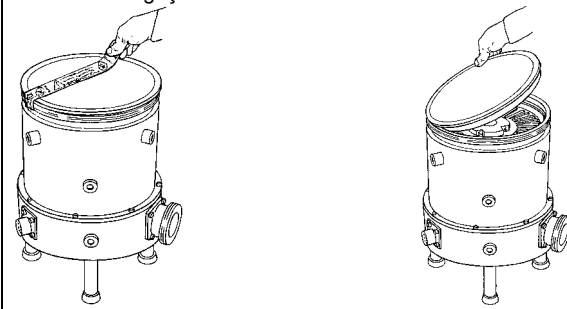

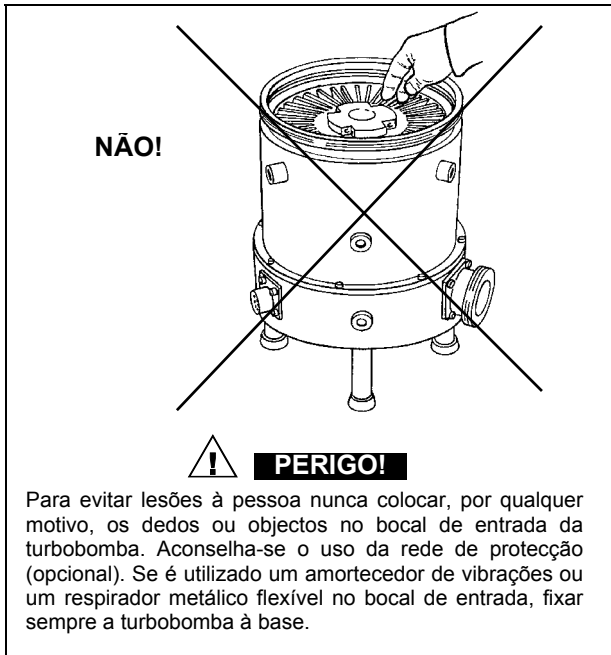

Existindo campos electromagnéticos, a bomba deve ser protegida com blindagens adequadas. Ver o apêndice "Technical Information" para maiores detalhes.

As bombas turbomoleculares da série Turbo-V1800A devem ser utilizadas somente com um dos controladores Varian específicos (série 969-9561, 969-9461) e devem ser ligadas a uma bomba primária (ver esquema em "Technical Information").

A turbobomba deve ser instalada em posição vertical, ou em posição invertida com uma inclinação máxima em relação ao eixo vertical de 10°.

A bomba pode permanecer apoiada nos seus pés, ou ser suspensa através do flange de entrada. Fixar a turbobomba em posição estável ligando a flange de entrada da turbobomba a uma contraflange fixa capaz de resistir a um torque de 2814 Nm ao redor do próprio eixo.

A turbobomba com flange de entrada ISO, deve ser fixada às câmaras de vácuo através de bornes duplos ou simples. A tabela a seguir descreve o número de bornes necessários e com qual torque devem ser apertados.

FLANGE	TIPO DE BORNE	Nº	TORQUE
ISO 250	Borne duplo com rosca M10	6	22 Nm
	Borne simples com rosca M10	12	22 Nm

A turbobomba com flange de entrada ConFlat deve ser fixada à câmara de vácuo através de parafusos específicos da mecânica Varian. Para maiores detalhes, ver o apêndice "Technical Information".

Se a bomba apoiar nos seus pés, estes deverão ser fixados ao plano de apoio utilizando os furos rosqueados M6 existentes na base da bomba. Ditos furos são posicionados num anel com diâmetro de 285 mm (11,22 polegadas).

Para a instalação dos acessórios opcionais, ver "Technical Information".

UTILIZAÇÃO

Todas as instruções para o correcto funcionamento da turbobomba estão contidas no manual da unidade de controlo. Ler atentamente este manual antes da utilização.

Para atingir melhores pressões limite é possível aquecer o invólucro da bomba utilizando o aquecedor opcional. Durante o eventual aquecimento da câmara a vácuo, a temperatura no flange de entrada não deve ser superior a 120 °C. Utilizar

sempre o resfriamento com água durante as operações de aquecimento.

Utilizar sempre o resfriamento com água durante as operações de aquecimento (ver o apêndice "Technical Information" para os detalhes relativos à ligação à bomba do resfriamento de água).



Não tocar a turbobomba e os seus eventuais acessórios durante as operações de aquecimento. A elevada temperatura pode causar lesões às pessoas.



Para a saída de ar da bomba utilizar ar ou gás inerte sem poeiras ou partículas. A pressão de entrada através da porta específica deve ser inferior a 2 bar (além da pressão atmosférica).



Evitar colisões ou deslocamentos bruscos da turbobomba quando está a funcionar. Os rolamentos poderiam sofrer danos.



Para bombear gases agressivos, estas bombas estão equipadas com uma porta específica através da qual é necessário fornecer à bomba um fluxo de gás inerte (Azoto ou Argon) para proteger os rolamentos (ver o apêndice "Technical Information").



Quando a bomba é utilizada para bombear gases tóxicos, inflamáveis ou radioactivos, seguir os procedimentos adequados típicos para cada gás.

Não usar a bomba na presença de gases explosivos.

MANUTENÇÃO

As bombas da série Turbo-V1800A não requerem qualquer manutenção. Qualquer operação deve ser efectuada por pessoal autorizado.



Antes de efectuar qualquer operação na turbobomba desligar o conector de alimentação, introduzir ar na bomba abrindo a válvula específica, aguardar até a completa paragem do rotor e até que a temperatura superficial da bomba seja inferior a 50 °C.

Em caso de defeito é possível usufruir do serviço de reparação Varian ou do "Varian advanced exchange service", que permite obter uma bomba regenerada que substitua a bomba com defeito.

OBS.

Antes de enviar ao construtor uma bomba para reparações ou advanced exchange service, é indispensável preencher e enviar ao escritório local de vendas a ficha "Segurança e Saúde" anexa ao presente manual de instruções. A cópia da mesma deve ser colocada na embalagem da bomba antes da expedição.

Caso uma bomba deva ser destruída, proceder à sua eliminação respeitando as normas nacionais específicas.

ALGEMENE INFORMATIE

Deze apparatuur is bestemd voor beroepsmatig gebruik. De gebruiker wordt verzocht aandachtig deze handleiding en alle overige door Varian verstrekte informatie door te lezen alvorens het apparaat in gebruik te nemen. Varian acht zich niet aansprakelijk voor de gevolgen van het niet of gedeeltelijk in acht nemen van de aanwijzingen, onoordeelkundig gebruik door niet hiervoor opgeleid personeel, reparaties waarvoor geen toestemming is verkregen of gebruik in strijd met de specifieke nationale wetgeving.

De pompen van de serie Turbo-V1800A zijn turbomoleculaire pompen voor hoge en ultrahoge vacuümtoepassingen, die in staat zijn om elk type gas of gasverbinding te pompen. Ze zijn niet geschikt voor het pompen van vloeistoffen of vaste deeltjes.

Het pompeffect wordt verkregen door een zeer snel draaiende turbine (max. 27.000 toeren/min.) die aangedreven wordt door een elektrische draaistroommotor met hoog rendement. De Turbo-V1800A pompen zijn volledig vrij van verontreinigingen en zijn dus ook geschikt voor toepassingen die een "schoon vacuüm" verlangen.

In de volgende paragrafen is alle informatie vermeld om de veiligheid van de operator tijdens het gebruik van de apparatuur te verzekeren. Gedetailleerde informatie is te vinden in de bijlage "Technical information".

Deze handleiding gebruikt de volgende symbolen:



GEVAAR!

Bij dit symbool staat tekst die de aandacht van de operator vestigt op een speciale procedure of methode die, indien niet correct uitgevoerd, ernstig lichamelijk letsel kan veroorzaken.



ATTENTIE!

Bij dit symbool staat tekst met procedures die, indien niet opgevolgd, schade aan apparatuur kunnen veroorzaken.

OPMERKING

De opmerkingen bevatten belangrijke informatie die uit de tekst is gelicht.

OPSLAG

Tijdens het transport en de opslag van de pompen moeten de volgende omgevingscondities aanwezig zijn:

- temperatuur: van -20°C tot +70°C
- relatieve vochtigheid: 0 - 95% (niet condenserend)

Als de opslagperiode van lange duur is, de pomp met de SOFT START wijze opstarten (zie handleiding regeleenheid).

UITPAKKEN

De pomp wordt in een speciale beschermende verpakking geleverd; als er schade wordt geconstateerd die tijdens het transport veroorzaakt zou kunnen zijn, meteen contact opnemen met het plaatselijke verkoopkantoor.

Zorg er bij het uitpakken voor dat de pomp niet kan vallen of stoten te verduren krijgt.

Laat de verpakking niet ergens buiten achter. Het verpakkingsmateriaal is volledig recyclebaar en voldoet aan de EEG milieurichtlijn 85/399.



ATTENTIE!

Om ontgassingsproblemen te voorkomen, mogen de componenten die met het vacuüm in aanraking komen niet met de blote handen aangeraakt worden. Gebruik altijd wanten of een andere geschikte bescherming.

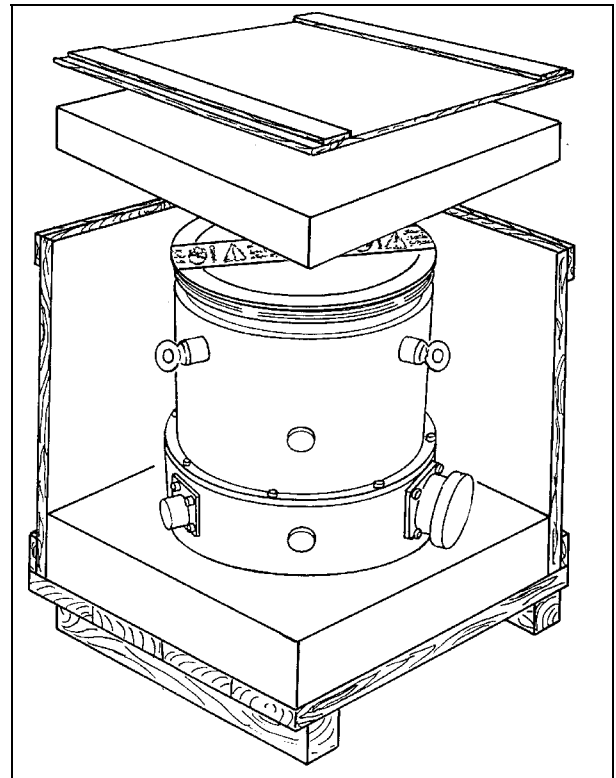

OPMERKING

De pomp kan niet beschadigd worden door eenvoudigweg aan de atmosfeer blootgesteld te worden. Toch wordt aangeraden om de pomp gesloten te houden zolang deze niet in het systeem wordt ingebouwd, zodat eventuele vervuiling door stof wordt voorkomen.

INSTALLATIE



GEVAAR!

De pomp moet in verband met haar gewicht met de juiste hefwerktuigen worden opgeheven en verplaatst.

De pomp mag niet geïnstalleerd en/of gebruikt worden in ruimten die blootgesteld zijn aan de weersomstandigheden (regen, vorst, sneeuw), stof, agressieve gassen, of in ruimten met explosiegevaar of zeer hoog brandgevaar.

Tijdens de werking moeten de volgende omgevingscondities aanwezig zijn:

- max. druk: 2 bar boven de atmosferische druk
- temperatuur: van +5°C tot +35°C
- relatieve vochtigheid: 0 - 95% (niet condenserend).

ATTENTIE!

Alleen op het moment waarop de turbopomp op het systeem wordt aangesloten mogen de sticker en de beschermdop verwijderd worden.

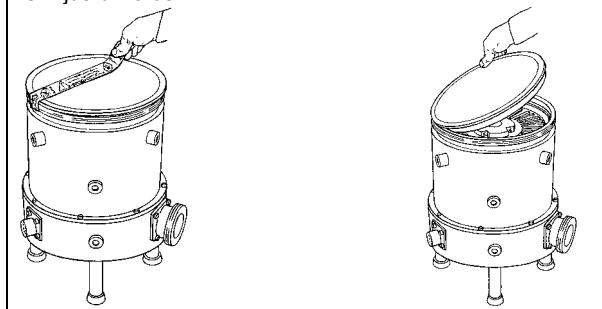

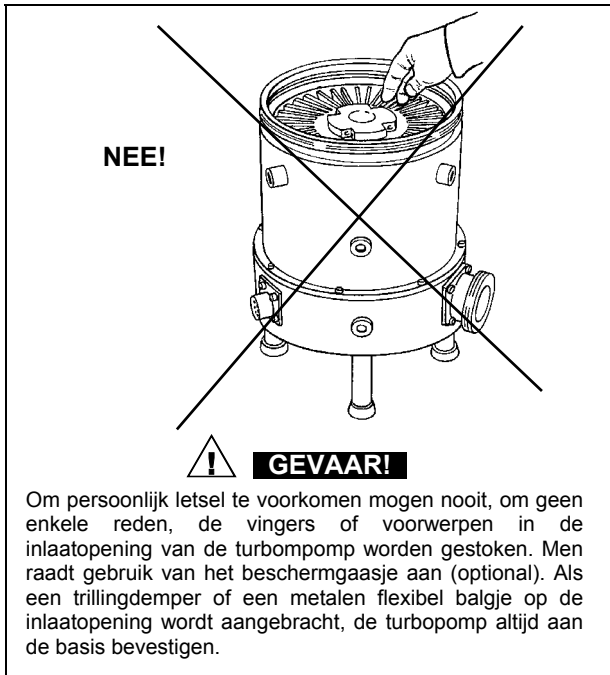

Bij aanwezigheid van magnetische velden moet de pomp op passende wijze afgeschermd worden. Zie de bijlage "Technical Information" voor meer informatie.

De turbomoleculaire pompen van de serie Turbo-V1800A mogen alleen gebruikt worden in combinatie met een van de speciale Varian controllers (serie 969-9561, 969-9461) en moeten aangesloten zijn op een primaire pomp (zie schema in "Technical Information").

De turbopomp moet in verticale stand worden geïnstalleerd of op haar kop, waarbij de hellingsgraad t.o.v. de verticale as maximaal 10° mag bedragen.

De pomp kan op haar pootjes worden gezet of met behulp van de inlaatflens worden opgehangen.

Bevestig de turbopomp in een stabiele positie en verbind de inlaatflens van de turbopomp met een vaste contraflens die een koppel van 2814 Nm rondom de eigen as kan verdragen.

De turbopomp met ISO inlaatflens moet aan de vacuümkamer worden verbonden met behulp van dubbele of enkelvoudige klemmen. De volgende tabel beschrijft het aantal benodigde klemmen en het aanhaalkoppel waarmee ze vastgezet moeten worden.

FLENS	KLEMTYPE	NR.	AANHAALKOPPEL
ISO 250	Dubbele klem met M10 schroefdraad	6	22 Nm
	Enkelvoudige klem met M10 schroefdraad	12	22 Nm

De turbopomp met ConFlat inlaatflens moet aan de vacuümkamer worden bevestigd met behulp van de speciale mechanische bevestigingselementen van Varian. Zie voor meer informatie de bijlage "Technical Information".

Als de pomp op haar pootjes wordt gezet, moeten deze pootjes aan het steunvlak worden bevestigd met behulp van M6 schroefdraadgaten die zich onder de pootjes moeten bevinden. Deze gaten bevinden zich op een cirkelomtrek met diameter van 285 mm (11,22 duim).

Zie "Technical Information" voor installatie van accessoires die als optie verkrijgbaar zijn.

GEBRUIK

Alle aanwijzingen voor de correcte werking van de turbopomp zijn in de handleiding van de regeleenheid vermeld. Lees aandachtig deze handleiding vóór ingebruikname door.

Om een betere grensdruk te bereiken, kan het pomphuis verwarmd worden met behulp van een optionele verwarmingsunit. Tijdens de eventuele verwarming van de vacuümkamer mag de temperatuur op de inlaatflens niet meer dan 120° C bedragen.

Pas tijdens het verwarmen altijd waterkoeling toe (zie bijlage "Technical Information" voor aanwijzingen over de aansluiting van de waterkoeling aan de pomp).



Raak de pomp en eventuele accessoires niet tijdens het verwarmen aan. De hoge temperatuur kan lichamelijk letsel veroorzaken.



Gebruik voor de luchttoevoer naar de pomp lucht of inert gas zonder stof of vaste deeltjes. De inlaatdruk via de hiervoor bestemde poort moet minder dan 2 bar (boven de atmosferische druk) bedragen.



Vermijd stoten of bruuske verplaatsingen wanneer de turbopomp in werking is. De lagers kunnen hier namelijk schade door oplopen.



Deze pompen zijn voor het pompen van agressieve gassen van een speciale poort voorzien, waardoor de pomp een stroom inert gas (stikstof of argon) ter bescherming van de lagers krijgt geleverd (zie bijlage "Technical Information").



Wanneer de pomp wordt gebruikt voor het pompen van brandbare, giftige of radioactieve gassen, moeten de procedures worden gevolgd die speciaal voor elk type gas zijn opgesteld.

Gebruik de pomp niet in aanwezigheid van explosieve gassen.

ONDERHOUD

De pompen van de serie Turbo-V1800A zijn onderhoudsvrij. Eventuele werkzaamheden moeten door bevoegd personeel worden uitgevoerd.



Alvorens werkzaamheden aan de turbopomp uit te voeren, de stekker verwijderen, de pomp met behulp van de hiervoor bestemde klep ontluichten en wachten totdat de rotor volledig stil staat en de oppervlaktetemperatuur van de pomp onder een temperatuur van 50 °C is gezakt.

In geval van storing is het mogelijk om de reparatiedienst van Varian of de "Varian advanced exchange service" in te schakelen: zo krijgt men een ruihpomp ter vervanging van de defecte pomp.

OPMERKING

Alvorens de pomp ter reparatie of ruil naar de fabrikant op te sturen, moet de bij deze handleiding gevoegde kaart "Veiligheid en Gezondheid" volledig ingevuld naar het plaatselijke verkoopkantoor worden gestuurd. Een kopie van deze kaart moet vóór versturing bij de pomp in de verpakking worden gevoegd.

Mocht de pomp gesloopt worden, ga dan overeenkomstig de specifieke nationale wetgeving te werk.

ALMENE OPLYSNINGER

Dette materiel er beregnet til professionel anvendelse. Brugeren bedes læse denne håndbog samt enhver yderligere vejledning, Varian har leveret, inden udstyret tages i brug. Varian er ikke ansvarlig, hvis vejledningen ikke er nøje fulgt, eller hvis den kun er delvist fulgt, og heller ikke hvis udstyret anvendes forkert af ukvalificeret personale, hvis der foretages uautoriserede indgreb på det, eller hvis udstyret benyttes på en måde, der står i kontrast til det pågældende lands særlige normer.

Turbo-V1800A serien omfatter turbomolekulære pumper til højvakuum og til ultra-højvakuum, der er i stand til at pumpe alle typer luftarter og luftforeninger. Denne serie er ikke egnet til at pumpe væsker eller faste partikler.

Pumpeeffekten opnås ved hjælp af en turbine, der roterer ved høj hastighed (max. 27000 omdr./min) drevet af en højeffektiv trefaset elektrisk motor. Turbo-V1800A pumperne er fuldstændig fri for forurenende stoffer og finder derfor god anvendelse, når der kræves et "rent" vakuum.

I det følgende gives alle nødvendige oplysninger for operatørens sikkerhed under brug af udstyret. For detaljerede oplysninger henvises til den vedlagte "Technical Information".

I denne håndbog findes følgende regler:



ADVARSEL!

Advarselne henkalder operatørens opmærksomhed på et indgreb eller en særlig handling, der kan forårsage alvorlig fare for kvæstelser, hvis den ikke udføres korrekt.



PAS PÅ!

Disse ord forekommer inden en arbejdsmetode, der skal overholdes for ikke at skabe risiko for skade på udstyret.

BEMÆRK

Bemærkningerne indeholder vigtige yderligere oplysninger.

OPLAGRING

Under transport og oplagring af pumpene skal følgende omgivelsesbetingelser være overholdt:

- temperatur: fra -20°C til +70°C
 - relativ fugtighed: 0 - 95% (ikke kondenserende)
- Hvis pumperne oplagres gennem lang tid, skal de sættes i gang på den såkaldte 'SOFT START' måde (se håndbogen til kontrolheden).

FORBEREDELSE TIL MONTERING

Pumpen leveres med en særlig beskyttelsesemballage. Kontakt vores lokale salgskontor, hvis der findes tegn på beskadigelse, der kan være sket under transporten.

Pas på at pumpen ikke falder på gulvet og at der ikke stødes til den under udpakningen.

Smid ikke emballagen væk ude i naturen. Al emballage er genbrugsmateriale i overensstemmelse med EF-direktiv 85/399 vedrørende miljøbeskyttelse.



PAS PÅ!

For at undgå afgangsproblemer skal man ikke røre med de bare hænder de dele, der vil blive udsat for vakuum. Brug altid handsker eller anden passende beskyttelse.

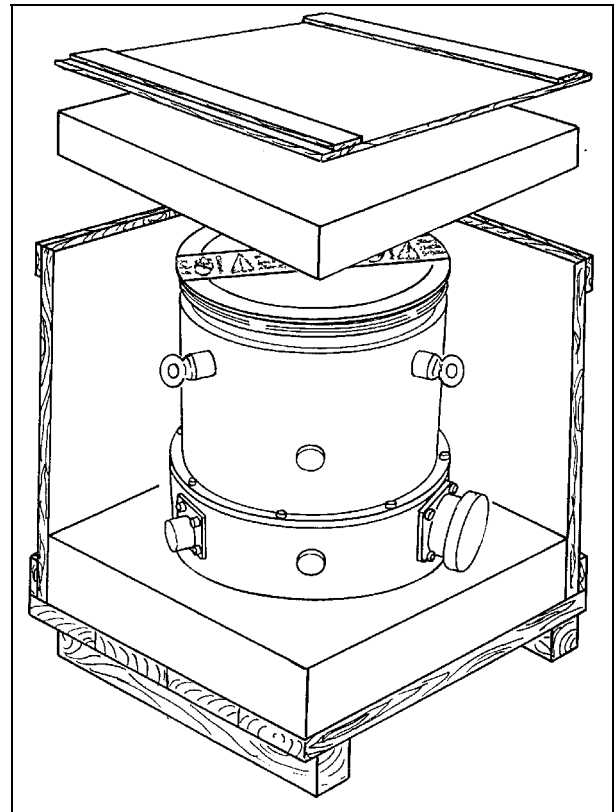

BEMÆRK

Pumpen kan ikke beskadiges ved blot at være udsat for den atmosfæriske luft. For at undgå forurening fra støv anbefales det dog, at pumpen holdes tilpakket, indtil den monteres i anlægget.

MONTERING



ADVARSEL!

Med hensyn til pumpens vægt må den kun flyttes med dertil egnet løfteudstyr.

Pumpen må ikke installeres eller bruges i omgivelser, der udsætter den for forvitring (regn, frost, sne), støv, ætsende luftarter, og heller ikke i omgivelser med eksplosionsfare eller stor brandfare.

Følgende betingelser skal overholdes under driften:

- maksimaltryk: 2 bar (over atmosfærisk tryk)
- temperatur: fra +5°C til +35°C
- relativ fugtighed: 0 - 95% (ikke kondenserende).



PAS PÅ!

Etiketten og beskyttelsesdækslet fjernes først i det øjeblik, turbopumpen tilsluttes anlægget.

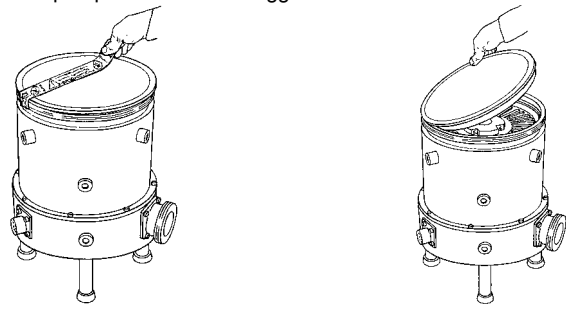

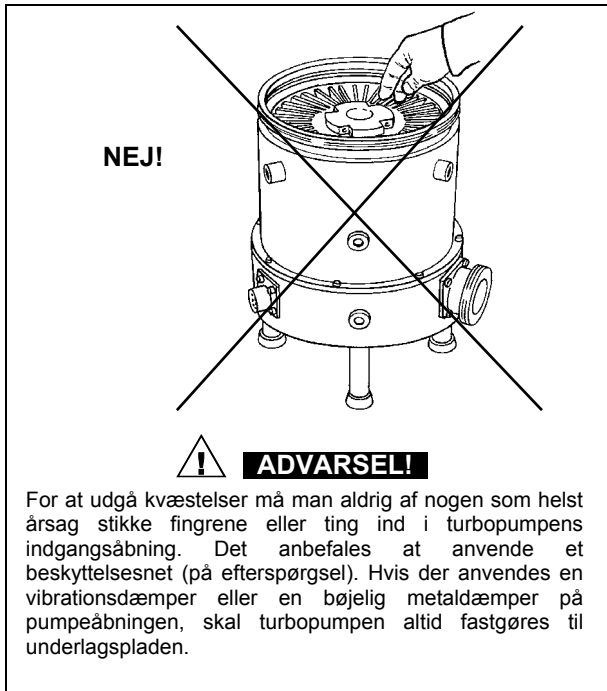

Hvis der findes magnetfelter må pumpen afskærmes. Se bilag "Technical Information" for yderligere detaljer.

Turbomolekylærpumperne i Turbo-V1800A serien må kun anvendes med en af de særlige Varian kontrolapparater (serie 969-9561, 969-9461) og skal forbindes med en primær Turbopumpen kan monteres i vertikal stilling, eller med bunden i vejret med en max. hældning på 10° i forhold til den vertikale akse.

Pumpen kan enten stå på sine fødder, eller hænges via indgangsflangen.

Turbopumpen fastspændes ved, at turbopumpens indgangsflange fastgøres til en fast modflange, der er i stand til at modstå et drejningsmoment på 2814 Nm omkring akse.

Turbopumperne med ISO indløbsflange skal fastspændes til vakuumkammeret med dobbelte eller enkelte klemmer. Følgende tabel angiver det nødvendige antal af klemmer og det anvendte tilspændingsmoment for de enkelte flangedimensioner.

FLANGE	KLEMMETYP	ANTAL	TILSPÆNDINGSMOMENT
ISO 250	Dobbelt klemme gevind M10	6	22 Nm
	Enkelt klemme gevind M10	12	22 Nm

Turbopumpen med indløbsflange ConFlat skal fastspændes til vakuumkammeret ved hjælp af de specielle fastgørelsesdele fra Varian. For detaljer henvises til "Teknisk information".

Hvis pumpen står på sine fødder, skal disse forankres til underlaget ved hjælp af M6-hullerne i nærheden af støttefødderne. Disse huller er anbragt på en cirkel med diameter 285 mm.

Se "Technical Information" for montering af optionals.

ANVENDELSE

Al vejledning angående turbopumpens korrekte drift er beskrevet i håndbogen til kontrolheden.

Læs den nævnte håndbog omhyggeligt før brugen.

For at opnå bedre grænsetryk kan pumpebeklædningen opvarmes. Hvis vakuumkammeret opvarmes, må temperaturen på indgangsflangen ikke overstige 120°C.

Brug altid vandafkøling under opvarmningen (se "Technical Information" vedrørende kølevandets tilslutning til pumpen).



ADVARSEL!

Rør ikke ved turbopumpen eller eventuelt tilbehør under opvarmningsmanøvrerne. Den høje temperatur kan forårsage kvæstelser på personer.

PAS PÅ!

Til pumpens luftaflob anvendes luft eller en inaktiv luftart, der er fri for støv og partikler. Indgangstrykket gennem den særlige åbning skal være under 2 bar.

PAS PÅ!

Undgå stød eller pludselig flytning af turbopumpen, mens den er i drift. Lejerne kan beskadiges.

PAS PÅ!

Til pumpning af ætsende luftarter er disse pumper forsynet med en særlig åbning, hvortil den passive luftart (argon eller kvælstof) skal sluttes for at beskytte lejerne.



ADVARSEL!

Når pumpen anvendes til pumpning af giftige, brandfarlige eller radioaktive gasser, skal de gældende forskrifter for den enkelte gastype strengt overholdes.

Pumpen må ikke anvendes i eksplosionsfarlige miljøer.

VEDLIGEHOLDELSE

Pumperne af TURBO-V1800A serien behøver ikke nogen vedligeholdelse. Ethvert indgreb på pumpen skal foretages af autoriseret personale.



ADVARSEL!

Inden der foretages noget som helst indgreb på turbopumpen, skal strømmen først afbrydes og luften lukkes ud af pumpen ved, at man åbner den særlige ventil og venter indtil rotoren er standset helt, og pumpens overfladetemperatur er lavere end 50°C.

Hvis pumpen går i stykker, kan man benytte sig af Varians reparationservice eller af Varians "Advanced Exchange Service", hvorved man kan få en repareret pumpe i bytte for den, der er gået i stykker.

BEMÆRK

Inden pumpen sendes tilbage til fabrikanten til reparation eller til "Advanced Exchange Service", skal man udfylde formularen "Sikkerhed og Helbred" vedlagt denne håndbog og tilsende den til den lokale forhandler. En kopi af formularen skal vedlægges i pakken med pumpen ved tilbagesendelsen.

Hvis en pumpe skal skrottes, skal dette foregå i overensstemmelse med det pågældende lands særlige love.

ALLMÄN INFORMATION

Utrustningen är avsedd för yrkesmässig användning. Användaren bör läsa denna bruksanvisning, samt övrig dokumentation från Varian före användning av utrustningen. Varian tar inget ansvar för skador helt eller delvis till följd av åsidosättande av instruktionerna, olämplig användning av person utan tillräcklig kunskap, obehörigt bruk av utrustningen eller hantering som strider mot gällande lokala föreskrifter.

Pumparna i Turbo-1800A-serien är turbomolekylära pumpar för höga och mycket höga vakuumbillämpningar. De kan användas för pumpning av alla typer av gas eller gasföreningar. De lämpar sig inte för pumpning av vätskor eller fasta partiklar.

Pumpningen åstadkoms med hjälp av en högvarv turbin (max 27000 varv/minut) som drivs av en trefas högeffektmotor. Inga tillsatssämnen används i Turbo-V1800A-seriens pumpar, som därför passar för tillämpningar som kräver ett "rent" vakuum.

De följande avsnitten innehåller all information som behövs för att garantera operatörens säkerhet under användningen. Detaljerade uppgifter finns i bilagan "Technical information".

I bruksanvisningen används följande standardrubriker:



VARNING!

Varningsmeddelandena informerar operatören om att en speciell procedur eller en viss typ av arbete måste utföras exakt enligt anvisningarna. I annat fall finns risk för svåra personskador.



VIKTIGT

Detta varningsmeddelande visas framför procedurer som måste följas exakt för att inte risk för maskinskada skall uppstå.

OBSERVERA

Detta visar på viktig information i texten.

FÖRVARING

Följande krav på omgivningsförhållanden gäller vid transport och förvaring av pumpen:

- temperatur: från -20°C till +70°C
- relativ luftfuktighet: 0 - 95% (utan kondens)

Efter lång förvaring skall pumpen startas med MJUKSTART - metoden (se bruksanvisningen för styrenheten).

FÖRBEREDELSE FÖR INSTALLATIONEN

Pumpen levereras i ett särskilt skyddande emballage. Kontakta det lokala försäljningskontoret om emballaget visar tecken på skador som kan ha uppstått under transporten.

Se till att pumpen inte tappas eller utsätts för stötar vid uppackningen.

Kasta inte packmaterialet i soporna. Materialet är återvinningsbart till 100% och uppfyller EU-direktiv 85/399 om miljöskydd.



VIKTIGT

Komponenter som skall utsättas för vakuum får inte hanteras med bara händer p g a kontamineringsrisken. Använd alltid handskar eller liknande skydd.

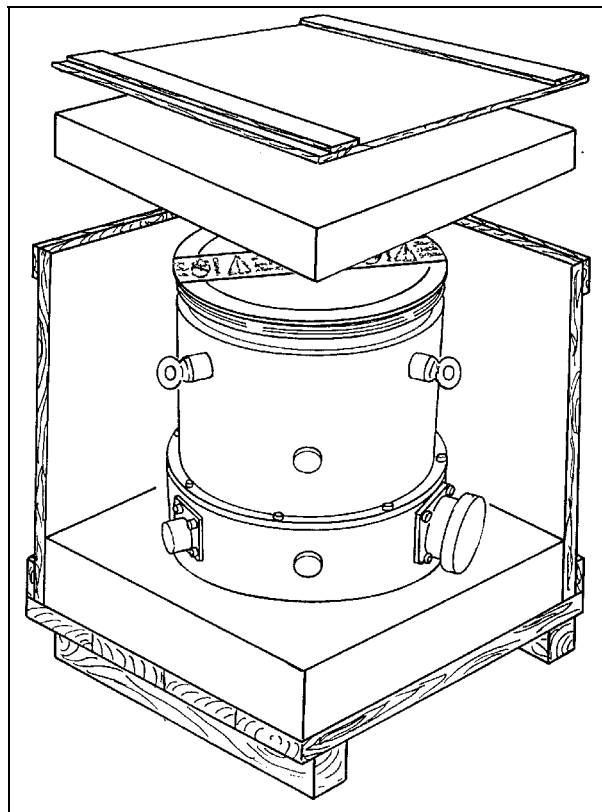

OBSERVERA

Normal påverkan från omgivningen kan inte skada pumpen. Trots det är det säkrast att hålla den stängd tills den har installerats i systemet, för att förhindra att det kommer in damm eller annat i den.

INSTALLATION



VARNING!

Pumpen måste p.g.a. sin vikt manövreras med speciella lyft- och flyttutrustningar.

Installera inte pumpen i miljöer som utsätts för påverkan från atmosfären (regn, snö, is), damm, aggressiva gaser, och inte heller i explosiv eller brandfarlig miljö.

Följande krav på omgivningsförhållanden gäller vid drift:

- maximitryck: 2 bar (över atmosfäriskt tryck)
- temperatur: från +5°C till +35°C
- relativ luftfuktighet: 0 - 95% (utan kondens)



VIKTIGT

Ta inte bort tejen och skyddskåpan innan turbopumpen har anslutits till systemet.

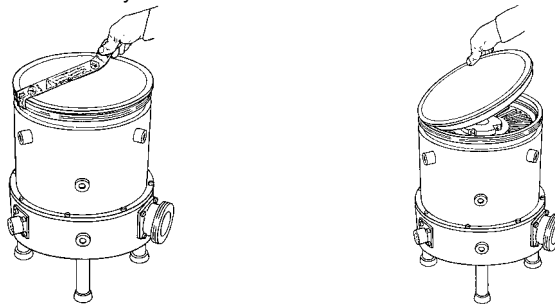

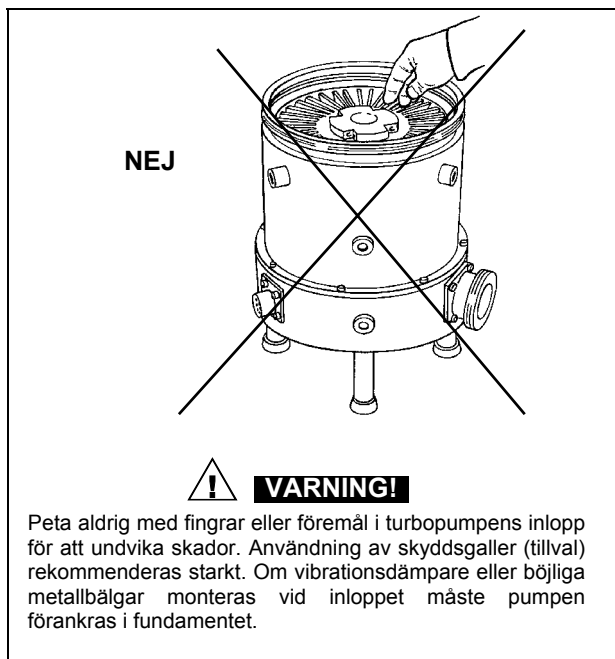

I närvaro av magnetfält skall pumpen skyddas med en särskild skärm. Se bilagan "Technical information" för ytterligare upplysningar.

Turbomolekylärpumparna i serien V1800A måste användas med en särskild styrenhet från Varian (serie 969-9561, 969-9461), och anslutas till en förpump (se schema i "Technical information").

Turbopumpen ska installeras i lodrät position eller uppochned med en max. lutning på 10° i förhållande till den lodräta axeln. Pumpen kan stödjas mot sina fötter eller vara upphängd med intagsflänsen.

Fäst turbopumpen i ett stabilt läge genom att ansluta pumpens intagsfläns till en fast fläns som måste tåla ett vridmoment på 2814 Nm runt sin axel.

Turbopumpen med ISO-intagsfläns ska fästas i vakuumkammaren med hjälp av dubbla eller enkla klamrar. Den följande tabellen beskriver nödvändigt antal klamrar och med vilket åtdragningsmoment de ska spännas.

FLÄNS	TYP AV KLAMMER	ANTAL	ÅTDRAGNINGSMOMENT
ISO 250	Dubbel klammer med gänga M10	6	22 Nm
	Enkel klammer med gänga M10	12	22 Nm

Turbopumparna med intagsfläns ConFlat ska fästas till vakuumkammaren med hjälp av Varian fästdelar. För detaljer hänvisas till bilaga "Technical Information".

Om pumpen stöds på sina fötter, fästs de till stödytan med de M6-gängade hål som är placerade i förhållande till stödfötterna. Dessa hål är placerade på en omkrets med diameter 285 mm. Installation av tillbehörsutrustning beskrivs i "Technical Information".

ANVÄNDNING

Anvisningar för riktig användning av turbopumpen finns i styrenhetens bruksanvisning.

Läs bruksanvisningen noga innan du startar pumpen.

För att förbättra tryckgränserna kan pumphuset värmas med ett särskilt värmeaggregat som finns som tillval. Under uppvärmningen av pumploppet får temperaturen vid inloppet aldrig bli högre än 120 °C.

Under uppvärmningen måste vattenkylningen användas. (se bilaga "Technical Information" för detaljer om pumpens anslutning till vattenkylning).



Vidrör inte turbopumpen eller några tillbehör under uppvärmningen för att undvika brännskador.



Använd luft eller ädelgas, fri från damm och partiklar för luftning av pumpen. Trycket vid inloppet får vara högst 2 bar (över atmosfäriskt tryck).



Undvik stötar eller plötsliga rörelser av pumpen under drift. I annat fall kan lagren skadas.



För pumpning av frätande gaser är dessa pumpar försedda med en speciell öppning igenom vilken man skall leda en ström av ädelgas (kväve eller argon) för att skydda lagren (se bilagan "Technical information").



Då pumpen används för pumpning av giftiga, lättantändliga eller radioaktiva typ, bör man följa de särskilda anvisningarna för varje enskild gas.

Använd ej pumpen i närheten av explosiva gaser.

UNDERHÅLL

Pumparna i Turbo-V1800A-serien är underhållsfria. Allt servicearbete måste utföras av auktoriserad personal.



Innan något arbete utförs på turbopumpen måste pumpens strömförsörjning brytas och pumpen luftas genom att den aktuella ventilen öppnas. Vänta sedan tills rotorn stannat samt tills pumpens yttemperatur är lägre än 50°C.

Om pumpen havererar, kontakta Varian reparationsverkstad eller Varian utbytesservice, som kan ersätta pumpen med en renoverad pump.

OBSERVERA

Innan pumpen lämnas in till tillverkaren för reparation eller utbyte mot en renoverad enhet, måste "hälsa- och säkerhetsbladet" som medföljer bruksanvisningen fyllas i och skickas in till den lokala återförsäljaren. Bifoga dessutom en kopia av bladet med pumpen.

Skrotning av pumpen skall ske enligt gällande lagstiftning.

GENERELL INFORMASJON

Dette utstyret er beregnet til bruk av profesjonelle brukere. Brukeren bør lese denne brukerveiledningen og all annen informasjon fra Varian før utstyret tas i bruk. Varian kan ikke holdes ansvarlig for hendelser som skjer på grunn av manglende oppfølging av disse instruksjonene, selv delvis, feilaktig bruk av utrent personell, ikke autoriserte endringer av utstyret eller handlinger som på noen måte er i strid med nasjonale bestemmelser.

Turbo-V1800A serien med pumper er turbo-molekulære pumper for bruk i høy- eller ultrahøye vakuumanlegg, og kan pumpe nesten alle typer gass eller gassforening. De er ikke beregnet for å pumpe væsker eller faste partikler.

Pumpingen oppnås med en høyhastighetsturbin (maks. 27000 opm) koplet til en trefaset elektrisk motor. Turbo-V1800A pumper har ingen forurensende stoffer og er derfor egnet for anlegg med behov for "rene" vakuu.

De følgende avsnitt inneholder all informasjon som er nødvendig for å sikre brukeren når utstyret er i bruk. For mer detaljert bruk vises det til tillegget "Teknisk informasjon".

Denne manualen bruker følgende standardprotokoll:



ADVARSEL!

Disse meldingene skal tiltrekke seg brukerens oppmerksomhet til en spesiell fremgangsmåte eller praksis som, hvis den ikke følges, kan medføre alvorlige skader.



FORSIKTIG

Denne advarselen vises foran fremgangsmåter som, dersom de ikke følges, kan føre til at utstyret skades.

MERK

Merknadene inneholder viktig informasjon som er hentet fra teksten.

LAGRING

Når pumpene transporteres eller lagres, må følgende miljømessige krav oppfylles:

- temperatur: fra -20°C til +70°C
- relativ fuktighet: 0 - 95% (uten kondens)

Skal utstyret lagres lengre, må pumpen MYKSTARTES (se kontrollenhetens manual).

KLARGJØRE TIL INSTALLASJON

Pumpen leveres i en spesiell beskyttelsesemballasje. Viser denne tegn på skader som kan ha oppstått under transporten, må du ta kontakt med det lokale salgskontoret.

Når pumpen pakkes ut, må du se til at den ikke slippes ned eller utsettes for noen form for støt.

Emballasjen må ikke kastes på en ulovlig måte. Alle materialer er 100% resirkulerbare og er i samsvar med EU-direktiv 85/399 om miljøbeskyttelse.



FORSIKTIG

For å unngå avgassingsproblemer, må ingen del som skal utsettes for vakuu håndteres med bare hendene. Bruk alltid hansker eller andre og passende verneutstyr.

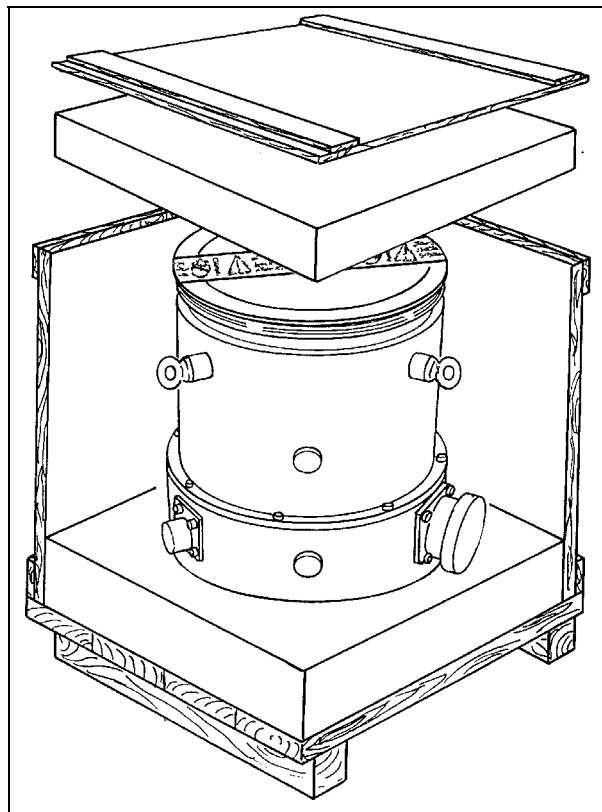

MERK

Normale miljømessige belastninger kan ikke ødelegge pumpen. Likevel anbefaler vi å holde den lukket til den er montert i systemet, slik at den ikke forurenses eller utsettes for nedstøving.

INSTALLASJON



ADVARSEL!

Med hensyn til pumpens vekt må den bare flyttes ved hjelp av et dertil bestemt løfteutstyr.

Ikke installer eller bruk pumpen i miljøer som utsettes for regn, snø eller is, støv, aggressive gasser, eksplosjonsfarlige miljøer eller miljøer med stor brannfare.

Under bruk må følgende forhold respekteres:

- maksimalt trykk: 2 bar (over atmosfærisk trykk)
- temperatur: fra +5°C til +35°C
- relativ fuktighet: 0 - 95% (uten kondens)



FORSIKTIG

Ikke fjern klebemerket og det beskyttende dekslet før turbopumpen skal festes til systemet

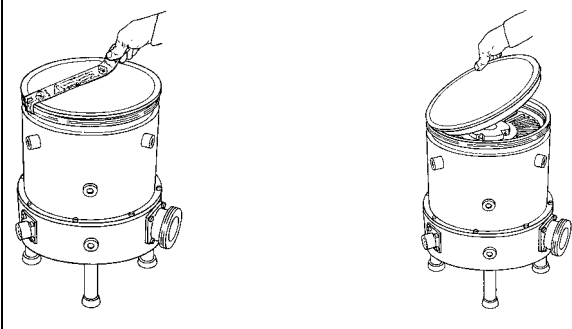

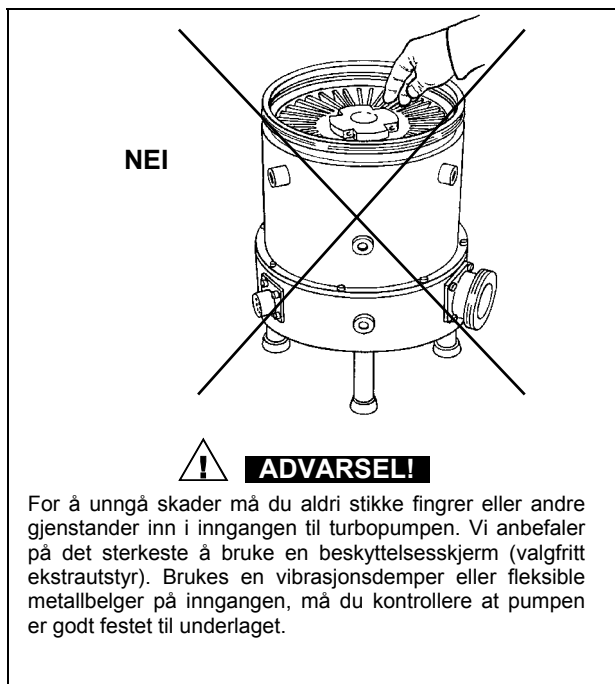

Ved magnetfelt må pumpen beskyttes av dertil egnede skjermer. Se "Teknisk informasjon" for detaljer.

Turbo-V1800A serien turbo-molekulære pumper må kun brukes med en av de spesielle Varian kontrollere (serie 969-9561, 969-9451), og må koples til hovedpumpen (se skjema i "Teknisk informasjon").

Turbopumpen kan monteres i vertikal stilling eller opp-og-nedvendt, med en maks. helling på 10° i forhold til den vertikale akselen.

Pumpen kan stå på føttene sine eller henges ved hjelp av en inngangsfleis.

Fest turbopumpen i en stabil stilling med inngangsfleisen festet mot en kopplingsfleis med et dreiemoment på 2814 Nm rundt akselen.

Turbopumpene med ISO innløpsfleis skal festes til vakuumkanteret med dobbel eller enkle klemmer. Følgende tabell angir det nødvendige antall klemmer og det relevante strammemomentet for de enkelte fleisdimensjonene.

FLEIS	TYPE KLEMME	ANTALL	STRAMME-MOMENT
ISO 250	Dobbel klemme gjenge M10	6	22 Nm
	Enkel klemme gjenge M10	12	22 Nm

Turbopumpen med innløpsfleis ConFlat skal festes på vakuumkanteret ved hjelp av de spesielle låsedelene fra Varian. For detaljer henvises det til "Teknisk informasjon".

Hvis pumpen står på føttene sine, festes disse til fundamentet ved hjelp av M6-hullene i nærheten av støtteføttene. Disse hullene er plasserte på en sirkel med diameter 285 mm.

For installasjon av tilleggsutstyr vises det til "Teknisk informasjon".

BRUK

Alle instruksjoner for korrekt bruk av turbopumpen finnes i kontrollenhetens manual.

Les nøye gjennom denne manualen før pumpen tas i bruk.

For å øke trykkgrensene kan pumpehuset varmes opp med en varmer som kan fås som ekstrautstyr. Mens oppvarmingen av kammeret pågår må temperaturen ved inngangsfleisen ikke overskride 120°C.

Bruk alltid vannavkjøling under oppvarmingen (se "Teknisk informasjon om tilkopling av pumpens kjølevannsledninger).



ADVARSEL!

Ikke berør turbopumpen eller noe av tilleggsutstyret under oppvarmingen. De høye temperaturene kan føre til brannskader.



FORSIKTIG

Bruk støv- og partikkelfri luft eller inaktiv gass ved lufting av pumpen. Trykket ved inngangen må ikke være mindre enn 2 bar (over atmosfærisk trykk).



FORSIKTIG

Unngå støt eller brå bevegelser av pumpen når den er i bruk. Dette kan føre til at lagrene skades.



FORSIKTIG

Ved pumping av etsende gasser er disse pumpene utstyrt med en spesiell åpning. Til denne åpningen skal flyt av inaktive gasser (argon eller kvelstoff) koples for å beskytte lagrene (se "Teknisk informasjon").



ADVARSEL!

Når pumpen brukes for å pumpe giftige, brannfarlige eller radioaktive gasser skal de relevante forskriftene for de enkelte gassstypene følges.

Pumpen skal ikke brukes i eksplosjonsfarlige miljøer.

VEDLIKEHOLD

Turbo-V1800A serien pumper er vedlikeholdsfrie. Alt arbeid på pumpen må kun utføres av autorisert personell.



ADVARSEL!

Før noe arbeid gjøres på turbopumpen må den frakoples tilførselen, den må luftes ved å åpne den aktuelle ventilen og deretter vente til rotoren har stanset og pumpens overflatetemperatur er lavere enn 50°C.

Dersom pumpen stanser, må du ta kontakt med Varians reparasjonsservice eller med Varians avanserte bytteservice som kan tilby overholte pumper til erstatning for den ødelagte pumpen.

MERK

Før pumpen returneres til produsenten for reparasjon, eller som innbytte for en overholt pumpe, må det vedlagte skjemaet "Helse og sikkerhet" fylles inn og sendes til det lokale salgskontoret. En kopi av dette arket må vedlegges pumpen som sendes tilbake.

Dersom en pumpe skal kasseres, må dette skje i henhold til nasjonale bestemmelser.

YLEISIÄ TIETOJA

Tämä laite on tarkoitettu ammattimaiseen käyttöön. Ennen laitteen käyttöönottoa tulee käyttäjän lukea huolellisesti mukana seuraava käyttöohje sekä kaikki muu Varianin toimittama lisätieto. Varian ei ota vastuuta seurauksista, jotka johtuvat laitteen käyttöohjeiden täydestä tai osittaisesta laiminlyönnistä, ammattitaidottoman henkilön virheellisestä laitteen käytöstä, valtuuttamattomista toimenpiteistä tai kansallisen lainsäädännön vastaisesta käytöstä.

Turbo-V1800A sarjan pumput ovat korkean ja ultrakorkean tyhjiön käyttöön tarkoitettuja kaikyntyyppisiä kaasuja tai kaasukoostumien pumppaavia turbomolekyylipumppuja. Ne eivät sovellu nesteiden tai kiinteiden hiukkasten pumppaukseen.

Pumppaus saadaan aikaan korkealla nopeudella (27000 kierrosta/min. max) pyörivän turbiinin avulla, jonka käynnistää korkeatehoinen kolmivaiheinen sähkömoottori. Turbo-V1800A -sarjan pumppuissa ei ole lainkaan likaavia aineita, joten ne soveltuvat myös "puhdasta" tyhjiötä vaativiin käyttötarpeisiin.

Seuraavilla sivuilla on luettavissa kaikki tarpeellinen tieto laitteen käyttäjän turvallisuuden takaamiseksi laitteen käytön aikana. Yksityiskohtaista tietoa saa osasta "Technical Information".

Tämä käsikirja käyttää seuraavanlaisia merkintöjä:



VAARA!

Vaara-merkit saavat käyttäjän kiinnittämään huomion erityiseen käyttö- tai toimintatapaan, joiden vääränlainen suoritus voi johtaa vakaviin henkilövaurioihin.



HUOMIO

Huomio-merkit ovat nähtävissä ennen toimintatapoja, joiden laiminlyönti voi johtaa laitteen vahingoittumiseen.

HUOMAUTUS

Huomautuksissa käyvät ilmi tekstissä käsitellyt tärkeät tiedot.

VARASTOINTI

Pumppujen kuljetuksen ja varastoinnin aikana täytyy seuraavien ympäristöä koskevien ehtojen olla täytettyinä:

- lämpötila: - 20°C - +70°C
- suhteellinen kosteus: 0 - 95% (ei tiivistävä)

Jos varastointiaika on hyvin pitkä, tulee pumppu käynnistää SOFT START-tavalla (katso valvojan käyttökirja).

VALMISTELUT ASENNUSTA VARTEN

Pumpun toimitus tapahtuu erityisessä suojaavassa pakkauksessa; mikäli havaittavissa on mahdollisesti kuljetuksen aikana tapahtuneita vaurioita, ottakaa yhteys paikalliseen myyntitoimistoon.

Pakkauksen purkamisen aikana tulee varoa erityisesti pumpun putoamista tai siihen kohdistuvia iskuja.

Pakkausta ei tule jättää ympäristöön. Pakkausmateriaali on täysin kierrätettävä ja se vastaa EEC 85/399 direktiiviä ympäristön suojelusta.



HUOMIO

Jotta kaasun poistumisongelmilta vältyttäisiin, ei tyhjiön tarkoitettuihin osiin tule koskea paljain käsin. Hanskojen tai muun sopivan suojan käyttö on tarpeellinen.

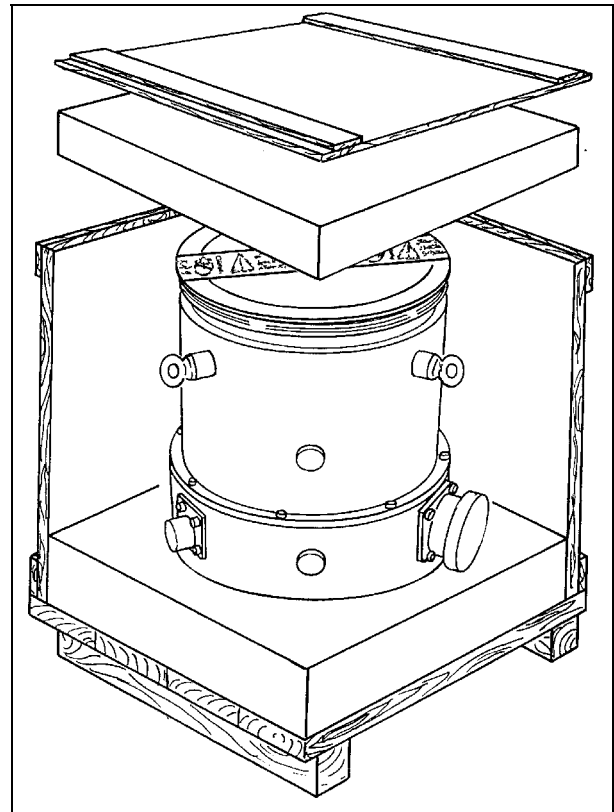

HUOMAUTUS

Pumppu ei vahingoitu sen ollessa yksinkertaisesti avoinna. On kuitenkin suositeltavaa pitää se suljettuna kunnes se kytketään järjestelmään, jotta vältettäisiin sen mahdollinen saastuminen pölyltä.

ASENNUS



VAARA!

Pumppua tulee sen painosta johtuen käsitellä asianmukaisten nosto- ja siirtovälineiden avulla.

Pumppua ei tule asentaa eikä käyttää ympäristössä, missä se joutuu kosketuksiin sateen, jään tai lumen, pölyn tai aggressiivisten kaasujen kanssa tai joissa on olemassa räjähdys- tai tulipalovaara.

Käytön aikana on tarpeellista noudattaa seuraavia ympäristöä koskevia ehtoja:

- maksimipaine: 2 bar, paitsi atmosfäärinen paine
- lämpötila: + 5°C - +35°C
- suhteellinen kosteus: 0 - 95 % (ei tiivistävä)



HUOMIO

Irrottakaa tarra ja poistakaa suojakansi sillä hetkellä kun turbopumppu liitetään järjestelmään.

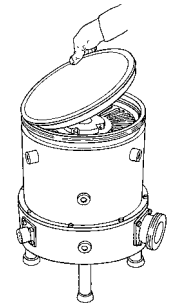
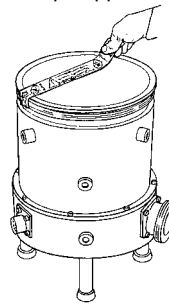

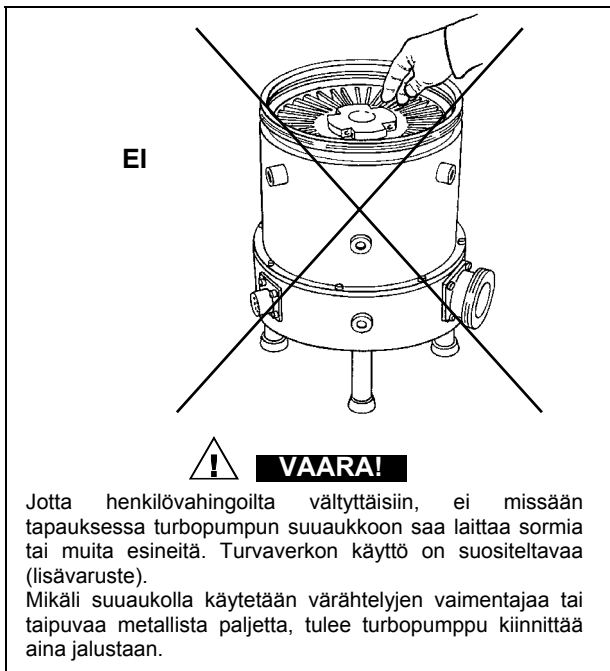

Mikäli magneettikenttijiä on läsnä pumppu tulee suojata tähän tarkoitukseen olevilla suojilla. Lidä tietoja löytyy "Technical Information"-liitteestä.

Sarjan Turbo-V1800A turbomolekyyli-pumppuja tulee käyttää ainoastaan niihin sopivien Varian-valvojen kanssa (sarja 969-9551, 969-9461) ja niiden tulee olla yhdistettyinä pääpumppuun (katso kaaviota osasta "Technical Information").

Turbopumppu tulee asentaa pystyasentoon tai ylösalaisin, niin että se on pystyakselista katsoen kallellaan enintään 10°.

Pumppu voidaan tukea jalkojensa varaan tai se voidaan asettaa riippuvaan asentoon sisääntulolaipan avulla.

Turbopumppu tulee kiinnittää vakaaseen asentoon liittämällä turbopumpun sisääntulolaippa kiinteään vastalaippaan, joka kannattaa 2814 Nm momenttia akselinsa ympärillä.

Turbopumppu ISO-sisääntulolaipalla tulee kiinnittää tyhjiökammariin kaksoiskiinnikkeillä tai yksinkertaisilla kiinnikkeillä. Seuraava taulukko sisältää tarvittavien kiinnikkeiden määrän ja niiden kiristysmomentit.

LAIPPA	KIINNIKE	MÄÄRÄ	KIRISTYSMO- MENTTI
ISO 250	Kaksoiskiinnike kierteitys M10	6	22 Nm
	Yksinkertainen kiinnike kierteitys M10	12	22 Nm

Turbopumppu ConFlat-sisääntulolaipalla tulee kiinnittää tyhjiökammariin sopivien Varianin mekaanisten varusteiden avulla. Lisätietoja löytyy "Technical Information"-liitteestä.

Mikäli pumppu on asennettu jalkojensa varaan, jalat tulee kiinnittää tukitasoon käyttämällä siihen tehtyjä, tukijalkoja vastaavia kiertisreikiä M6. Nämä reiät on sijoitettu läpimitaltaan 285 mm olevaan ympyrään.

Lisälaitteiden asennusohjeet ovat "Technical Information" osassa.

KÄYTTÖ

Turbopumpun oikeaoppiseen käyttöön tarvittavat ohjeet löytyvät valvojan käsikirjasta.

Lukekaa huolellisesti kyseinen käsikirja ennen käyttöönottoa. Jotta saavutettaisiin paremmat rajapaineet, on pumpun kotelon kuumentaminen mahdollista käyttämällä lisätilauksesta saatavaa kuumenninta. Tyhjiökammion mahdollisen kuumentamisen aikana ei sisäänjohtavan laipan lämpötila saa olla yli 120 °C.

Käyttäkää aina kuumentamisen aikana vettä jäähdytykseen (ks. "Technical information" -osaa pumpun vesijäähdytyskytkentöjä varten).



VAARA!

Älkää koskeko turbopumppuun tai sen lisäosiin kuumentamisen aikana. Korkea lämpötila voi saada aikaan henkilöiden loukkaantumisia.



HUOMIO

Päästettäessä pumppuun ilmaa tulee käyttää ilmaa tai jalokaasua, joissa ei ole pölyä tai hiukkasia. Sisäänjohtavan paineen siihen sopivan aukon läpi täytyy olla alle 2 bar:ia (paitsi atmosfäärinen paine).



HUOMIO

Vältäkä turbopumppuun kohdistuvia iskuja tai sen äkkinäistä liikuttamista sen ollessa käynnissä. Laakerit voivat vahingoittua.



HUOMIO

Aggressiivisten kaasujen pumppauksta varten mänä pumput on varustettu sopivalla aukolla jonka läpi tulee kulettaa pumppuun ei-aktiivisia kaasuja (typpi tai argooni) jotta laakerit suojataan (katso liite "Technical information").



VAARA!

Jolloin pumppua käytetään myrkyllisten, tulenvarallisten ja radioaktiivisten kaasujen pumppaamiseen tulee seurata joka kaasuun sopivaa menettelytapaa.

Älkää käytä pumppua räjähdysherkkien kaasujen lähellä.

HUOLTO

Sarjan Turbo-V1800A pumput eivät vaadi lainkaan huoltoa. Minkä tahansa toimenpiteen tulee suorittaa siihen valtuutettu henkilö.



VAARA!

Ennen minkään tyyppistä toimenpidettä ottaa pois päältä verkkovirta, päästää pumppuun ilmaa avaten siihen tarkoitettu venttiili ja odottaa roottorin täydellistä pysähtymistä ja että pumpun pintalämpö on alle 50°.

Laitteen vahingoittuessa on mahdollista käyttää Varianin korjauspalvelua tai "Varian advanced exchange service", joka mahdollistaa regeneroidun pumpun saamisen vahingoittuneen tilalle.

HUOMAUTUS

Ennen pumpun lähettämistä valmistajalle korjausta tai advanced exchange serviceä varten, on ehdottomasti täytettävä ja toimitettava paikalliseen myyntitoimistoon "Turvallisuus ja Terveys"-kaavake, joka löytyy liitteenä ohjekirjan mukana. Kyseisen kaavakkeen kopio tulee liittää pumpun pakkaukseen ennen sen lähettämistä.

Mikäli pumppu täytyy romuttaa, toimikaa kansallisen lainsäädännön määräämällä tavalla.

ΓΕΝΙΚΕΣ ΠΛΗΡΟΦΟΡΙΕΣ

Αυτή η συσκευή προορίζεται για επαγγελματική χρήση. Ο χρήστης θα πρέπει να διαβάσει προσεκτικά τις οδηγίες του παρόντος εγχειριδίου και οποιαδήποτε άλλη πρόσθετη πληροφορία που δίνει η ημερίαν, πριν από τη χρησιμοποίηση της συσκευής.

Η ημερίαν δεν φέρει καμία ευθύνη όσον αφορά την ολική ή μερική αθέτηση των οδηγιών, την ακατάλληλη χρήση εκ μέρους ανεκπαίδευτου προσωπικού, αυθαίρετες επεμβάσεις ή χρήση που δεν συμφωνεί με τις ειδικές εθνικές διατάξεις.

Οι αντλίες της κατηγορίας Turbo-V1800A είναι (στροβιλομοριακές) αντλίες (ή μοριακές τουρμπίνες) για εφαρμογές υψηλού και πολύ υψηλού κενού, ικανές να αντλήσουν κάθε είδους αέριο. Είναι ακατάλληλες για την άντληση υγρών ή στερεών σωματιδίων.

Η άντληση επιτυγχάνεται διαμέσου μίας τουρμπίνας που περιστρέφεται με μεγάλη ταχύτητα (το ανώτερο 27000 σ.α.λ.), η οποία κινείται από ένα τριφασικό ηλεκτρικό μοτέρ υψηλής απόδοσης. Οι αντλίες Turbo-V1800A δεν περιέχουν ρυπαντικούς παράγοντες, είναι κατάλληλες λοιπόν και για εφαρμογές που απαιτούν ένα καθαρό κενό.

Στις επόμενες παραγράφους αναφέρονται όλες οι απαραίτητες πληροφορίες που εγγυούνται την ασφάλεια του χειριστή κατά τη διάρκεια της χρησιμοποίησης της συσκευής. Λεπτομερείς πληροφορίες δίνονται στο παράρτημα " Τεχνικές Πληροφορίες ".
Αυτο το εγχειρίδιο χρησιμοποιεί τις ακόλουθες συμβάσεις:

**ΚΙΝΔΥΝΟΣ!**

Οι ενδείξεις κινδύνου ελκούν την προσοχή του χειριστή σε μια διαδικασία ή σε μια ειδική εργασία η οποία εάν δεν εκτελεστεί σωστά, θα μπορούσε να προκαλέσει σοβαρές προσωπικές βλάβες.

**ΠΡΟΣΟΧΗ!**

Οι ενδείξεις προσοχής εμφανίζονται πριν από τις διαδικασίες οι οποίες εάν δεν εκτελεστούν με προσοχή, θα μπορούσαν να προκαλέσουν ζημιές στη συσκευή.

ΣΗΜΕΙΩΣΗ

Οι σημειώσεις περιέχουν σημαντικές πληροφορίες που έχουν αποσπαστεί από το κείμενο.

ΑΠΟΘΗΚΕΥΣΗ

Κατά τη διάρκεια της μεταφοράς και της αποθήκευσης των αντλιών πρέπει να τηρούνται οι ακόλουθες περιβαλλοντικές συνθήκες:

- θερμοκρασία απο: - 20°C μέχρι +70°C
- σχετική υγρασία: 0 - 95% (ασυμπύκνωτη)

Εάν ο χρόνος αποθήκευσης ξεπερνάει τους 9 μήνες, η αντλία θα πρέπει να τεθεί σε κίνηση με τρόπο SOFT START (βλ. το εγχειρίδιο της μονάδας ελέγχου).

ΠΡΟΕΤΟΙΜΑΣΙΑ ΓΙΑ ΤΗΝ ΕΓΚΑΤΑΣΤΑΣΗ

Η αντλία είναι εξοπλισμένη με μία ευρύχωρη προστατευτική συσκευασία. Αν υπάρχουν ενδείξεις βλάβης που θα μπορούσαν να έχουν προκληθεί κατά τη διάρκεια της μεταφοράς, συμβουλευτείτε το τοπικό τμήμα πωλήσεων. Κατά τη διάρκεια του ανοίγματος της συσκευασίας, δώστε ιδιαίτερη προσοχή έτσι ώστε να μην πέσει και να μην χτυπηθεί η αντλία.

Μην εγκαταλείπετε τη συσκευασία στο περιβάλλον. Το υλικό ανακυκλώνεται πλήρως και ανταποκρίνεται στην Οδηγία της Ε.Ε. 85/399 για τη διαφύλαξη του περιβάλλοντος.

**ΠΡΟΣΟΧΗ!**

Προκειμένου να αποφύγετε προβλήματα από την απελευθέρωση αερίου, μην αγγίζετε με γυμνά χέρια τα τμήματα που πρόκειται να εκτεθούν στο κενό. Να χρησιμοποιείτε πάντα γάντια ή άλλη κατάλληλη προστασία.

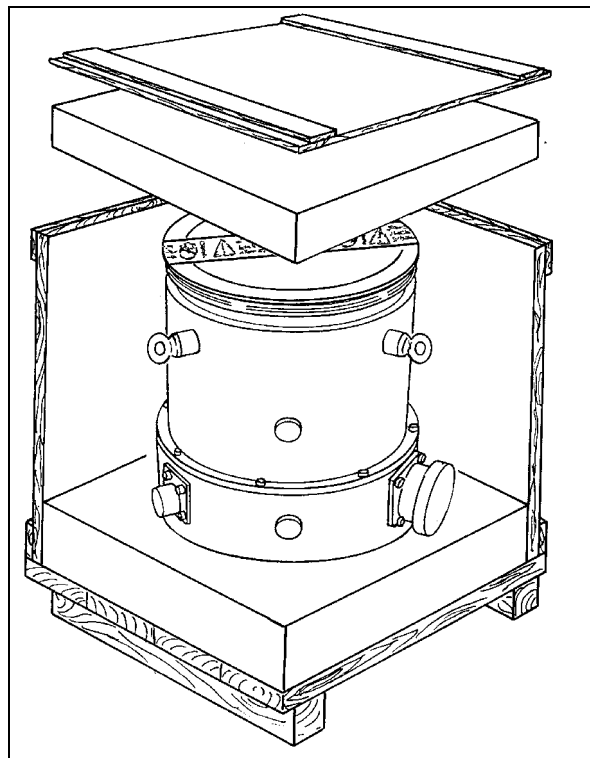
**ΣΗΜΕΙΩΣΗ**

Η αντλία δεν καταστρέφεται εάν απλώς εκτεθεί στον ατμοσφαιρικό αέρα. Σας συμβουλεύουμε όμως να την κρατήσετε κλειστή μέχρι τη στιγμή που θα εγκατασταθεί στο σύστημα, έτσι ώστε να αποφευχθεί η ενδεχόμενη ρύπανση από τη σκόνη.

ΕΓΚΑΤΑΣΤΑΣΗ**ΚΙΝΔΥΝΟΣ!**

Η αντλία, λόγω του βάρους της, πρέπει να μετακινηθεί διαμέσου κατάλληλων σύνεργων ανύψωσης και μετακίνησης.

Η αντλία δεν θα πρέπει να εγκατασταθεί και-ή να χρησιμοποιηθεί σε χώρους εκτεθειμένους σε ατμοσφαιρικούς παράγοντες (βροχή, πάγο, χιόνι), σκόνης, χημικά αέρια, σε χώρους όπου υπάρχει κίνδυνος έκρηξης ή κίνδυνος πυρκαγιάς. Κατά τη διάρκεια της λειτουργίας πρέπει να τηρούνται οι ακόλουθες συνθήκες περιβάλλοντος:

- μαξ. πίεση: 2 bar
- θερμοκρασία: από +5°C μέχρι +35°C
- σχετική υγρασία: 0 - 95 % (ασυμπύκνωτη).

ΠΡΟΣΟΧΗ!

Ξεκολλάτε το αυτοκόλλητο και βγάξτε το προστατευτικό καπάκι μόνον τη στιγμή της σύνδεσης της τουρμποαντλίας στο σύστημα.

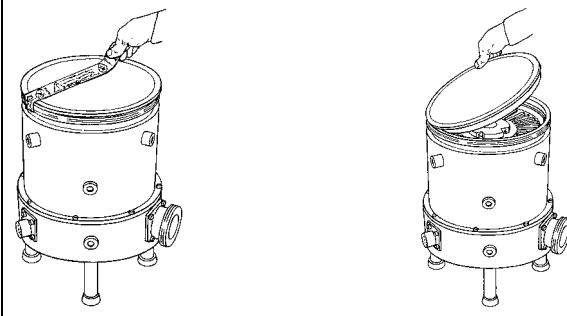

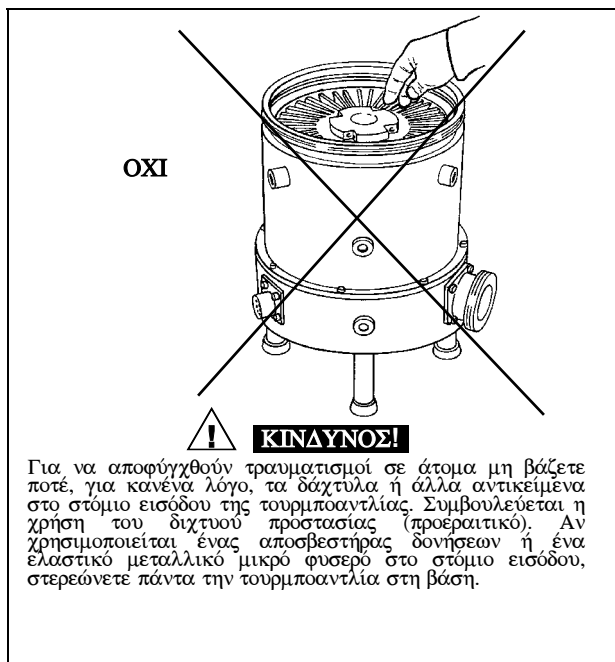

Σε μαγνητικά πεδία όπου η ένταση υπερβαίνει τα 10 mT είναι αναγκαία η κάλυψη της αντλίας με ένα σιδηρομαγνητικό κάλυμμα.

Οι τουρμποαερατικές αντλίες της σειράς Turbo-η1800A πρέπει να χρησιμοποιούνται μόνο με έναν από τους ειδικούς ελέγχους ηφιαριαν (σειρά 969-9561, 969-9461) και πρέπει να είναι συνδεδεμένες με μία πρωτεύουσα αντλία (βλέπε σχήμα στις "Τεχνικές Πληροφορίες").

Η τουρμποαντλία πρέπει να εγκατασταθεί σε κάθετη θέση, ή σε ανατρεπόμενη θέση με μία μέγιστη κλίση 10° σε σχέση με τον κάθετο άξονα.

Η αντλία μπορεί να παραμείνει ακουμπισμένη στα πόδια της, ή να αναρτηθεί διαμέσου της φλάντζας εισόδου.

Στερεώστε την τουρμποαντλία σε σταθερή θέση ενώνοντας τη φλάντζα εισόδου με μία σταθερή κόντροφλάντζα ικανή να συγκρατήσει ένα ζευγάρι 2814 Nm γύρω από τον άξονα της.

Η τουρμποαντλία με φλάντζα εισόδου ISO πρέπει να στερεωθεί στο θάλαμο κενού μέσω διπλών ή μονών μέγγενων. Η ακόλουθη ταμπέλα περιγράφει το απαραίτητο νούμερο μέγγενων και με ποιο ζεύγος βιδώματος να τα σφίξετε.

ΦΛΑΝΤΖ A	ΤΥΠΟΣ ΜΕΓΓΕΝΗΣ	N.	ΖΕΥΓΟΣ ΒΙΔΩΜΑΤΟΣ
ISO 250	Διπλή μέγγενη με ελίκωση M10	6	22 Nm
	Μονή μέγγενη με ελίκωση M10	12	22 Nm

Η τουρμποαντλία με φλάντζα εισόδου ΧονΦλατ πρέπει να στερεωθεί στο θάλαμο κενού μέσω των κατάλληλων μηχανικών εξαρτημάτων ηφιαριαν. Για περισσότερες λεπτομέρειες βλέπε την επιφυλλίδα "Τεχνικές Πληροφορίες".

Σε περίπτωση που η αντλία στηρίζεται στα πόδια της, αυτά τα τελευταία πρέπει να στερεωθούν στην επιφάνεια στήριξης χρησιμοποιώντας τις ελικοειδείς σπές M6 που έχουν τεθεί σε ανταπόκριση των ποδιών στήριξης. Αυτές οι σπές βρίσκονται σε έναν κύκλο με διάμετρο 285 μμ (11,22 ίντσες).

Για την εγκατάσταση των προαιρετικών αξεσουάρ, βλέπε "Τεχνικές Πληροφορίες".

ΧΡΗΣΗ

Ολες οι οδηγίες για τη σωστή λειτουργία της τουρμποαντλίας περιέχονται στο εγχειρίδιο ελέγχου.

Διαβάστε προσεκτικά αυτό το εγχειρίδιο πριν από τη χρήση. Για να επιτύχετε καλύτερες οριακές πιέσεις μπορείτε να θερμάνετε το περιβάλλον της αντλίας χρησιμοποιώντας τον έξτρα θερμαντή. Κατά τη διάρκεια της ενδεχόμενης θέρμανσης του θαλάμου κενού η θερμοκρασία στη φλάντζα εισόδου δεν πρέπει να ξεπερνάει τους 120°C. Κατά τη θέρμανση να χρησιμοποιείτε πάντα υγρή ψύξη (βλέπετε την επιφυλλίδα "Τεχνικές Πληροφορίες" για λεπτομέρειες σχετικά με τη σύνδεση της υγρής ψύξης στην αντλία).



ΚΙΝΔΥΝΟΣ!

Μην αγγίζετε την τουρμποαντλία και τα διάφορα εξαρτήματά της κατά τις εργασίες θέρμανσης. Η υψηλή θερμοκρασία μπορεί να προκαλέσει προσωπικές βλάβες.



ΠΡΟΣΟΧΗ!

Για να διοχετεύσετε με αέρα την αντλία χρησιμοποιήστε αέρα ή αδρανές αέριο καθαρό από σκόνη ή άλλα στοιχεία. Η πίεση εισόδου διαμέσου της ειδικής πόρτας, πρέπει να είναι μικρότερη από 2 bar.



ΠΡΟΣΟΧΗ!

Να αποφεύγονται χτυπήματα ή απότομες μετακινήσεις της τουρμποαντλίας όταν είναι σε λειτουργία. Θα μπορούσαν να δημιουργηθούν βλάβες στα ρουλεμάν.



ΠΡΟΣΟΧΗ!

Για την άντληση πολεμικών αερίων αυτές οι αντλίες είναι εφοδιασμένες με μια ειδική θυρίδα μέσω της οποίας είναι αναγκαία η διοχέτευση αδρανούς αερίου (Αζωτο ή Αργό) για να προστατευτούν τα εδράνα (βλέπετε την επιφυλλίδα "Τεχνικές Πληροφορίες").



ΚΙΝΔΥΝΟΣ!

Όταν η αντλία χρησιμοποιείται για την άντληση τοξικών, εύφλεκτων ή ραδιενεργών αερίων, ακολουθείτε τις κατάλληλες χαρακτηριστικές διαδικασίες του κάθε αερίου.

Μη χρησιμοποιείτε την αντλία παρουσία εκρηκτικών αερίων.

ΣΥΝΤΗΡΗΣΗ

Οι αντλίες της κατηγορίας Turbo - V1800A δε χρειάζονται καμμία συντήρηση. Οποιαδήποτε επέμβαση πρέπει να γίνεται από ειδικευμένο προσωπικό.



ΚΙΝΔΥΝΟΣ!

Πριν επιχειρήσετε οποιαδήποτε επέμβαση στην τουρμποαντλία, απουσυνδέστε το καλώδιο τροφοδοσίας, κάντε εξαέρωση στην αντλία ανοίγοντας την ειδική βαλβίδα και περιμένετε μέχρι να σταματήσει τελείως το μοτέρ.

Σε περίπτωση βλάβης μπορείτε να απευθυνθείτε στο σέρ'ιχε της ηφιαριαν ή στο "ηφιαριαν αδ'ανχεδ εξ'ιχανγε σερ'ιχε", που σας δίνει τη δυνατότητα να αντικαταστήσετε την χαλασμένη αντλία με μία άλλη ενισχυμένη.

ΣΗΜΕΙΩΣΗ

Πριν επιστρέψετε στον κατασκευαστή την αντλία για επισκευή ή για αδ'ανχεδ εξ'ιχανγε σερ'ιχε, είναι απαραίτητο να συμπληρώσετε και να παρουσιάσετε στο τοπικό Γραφείο Πωλήσεων, το έντυπο -Σιγουριά και υγεία- συννημμένο στο παρόν εγχειρίδιο οδηγιών. Αντίγραφο του ίδιου εντύπου πρέπει να υπάρχει μέσα στη συσκευασία της αντλίας πριν από την αποστολή.

Όταν πλέον πάψει να λειτουργεί η αντλία θα πρέπει να καταστραφεί σύμφωνα με τους ειδικούς εθνικούς κανονισμούς.

GENERAL INFORMATION

This equipment is destined for use by professionals. The user should read this instruction manual and any other additional information supplied by Varian before operating the equipment. Varian will not be held responsible for any events occurring due to non-compliance, even partial, with these instructions, improper use by untrained persons, non-authorized interference with the equipment or any action contrary to that provided for by specific national standards.

The Turbo-V 150HT series pumps are turbo-molecular pumps for high and ultra-high vacuum applications and can pump any type of gas or gas compound. They are not suitable for pumping liquids or solid particles. The pumping action is obtained through a high speed turbine (max. 62000 rpm) driven by a high-performance 3-phase electric motor. The Turbo-V 150HT pumps are free of contaminating agents and, therefore, are suitable for applications requiring a "clean" vacuum.

The following paragraphs contain all the information necessary to guarantee the safety of the operator when using the equipment. Detailed information is supplied in the appendix "Technical Information".

This manual uses the following standard protocol:

 **WARNING!**

The warning messages are for attracting the attention of the operator to a particular procedure or practice which, if not followed correctly, could lead to serious injury.

 **CAUTION**

The caution messages are displayed before procedures which, if not followed, could cause damage to the equipment.

NOTE

The notes contain important information taken from the text.

STORAGE

When transporting and storing the pumps, the following environmental requirements should not be exceeded:

- temperature: from -20° to +70 °C
- relative humidity: 0 - 95% (non-condensing)

If the storage time is long start the pump using the SOFT START mode (see control unit manual).

PREPARATION FOR INSTALLATION

The pump is supplied in a special protective packing. If this shows signs of damage which may have occurred during transport, contact your local sales office.

When unpacking the pump, be sure not to drop it and avoid any kind of sudden impact or shock vibration to it.

Do not dispose of the packing materials in an unauthorized manner. The material is 100% recyclable and complies with EEC Directive 85/399.

 **CAUTION**

In order to prevent outgassing problems, do not use bare hands to handle components which will be exposed to vacuum. Always use gloves or other appropriate protection.

NOTE

Normal exposure to the environment cannot damage the pump. Nevertheless, it is advisable to keep it closed until it is installed in the system, thus preventing any form of pollution by dust.

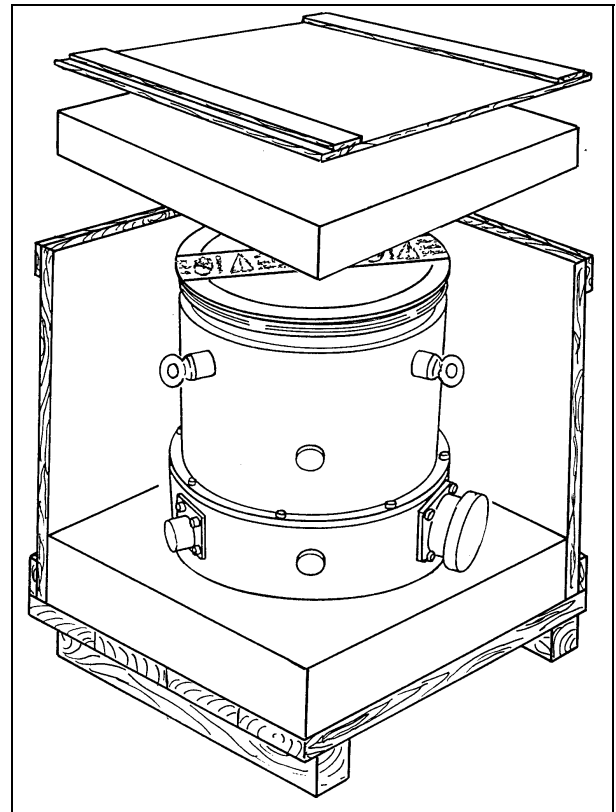

INSTALLATION

 **WARNING!**

Cause its weight, the pump must be handled by means of suitable moving and handling tools.

Do not install or use the pump in an environment exposed to atmospheric agents (rain, snow, ice), dust, aggressive gases, or in explosive environments or those with a high fire risk. During operation, the following environmental conditions must be respected:

- maximum pressure: 2 bar above atmospheric pressure
- temperature: from +5 °C to +35 °C
- relative humidity: 0 - 95% (non-condensing)

In the presence of magnetic fields the pump must be protected using a ferromagnetic shield. See the appendix "Technical Information" for detailed information.

 **CAUTION!**

Do not remove the adhesive and protective cap before connecting the turbopump to the system.

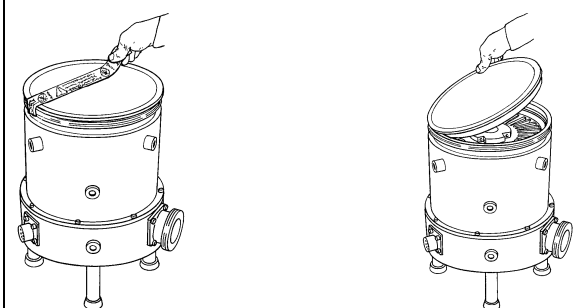

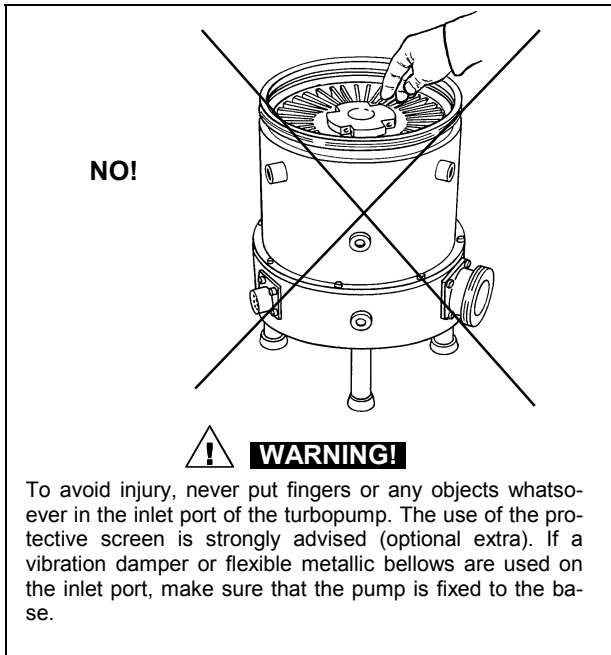

The Turbo - V 1800A series pumps must only be used with one of the special Varian controllers (series 969-9561, 969-9461) and must be connected to a primary pump (see "Technical Information").

The turbopump must be installed vertically or upside-down, with a maximum slope of 10°.

The pump can either rest on its support pedestal or it can be suspended from the high vacuum flange.

Fix the turbopump in a stable position connecting the inlet flange of the turbopump to a fixed counter-flange capable of withstanding a torque of 2814 Nm around its axis.

The turbopump with ISO inlet flange must be fixed to the vacuum chamber by means of clamps or claws. The following table shows, for each flange and fixing device, the necessary number of clamps or claws and the relevant fixing torque.

FLANGE	FIXING DEVICE	N.	FIXING TORQUE
ISO 250	M10 clamps	6	22 Nm
	M10 claws	12	22 Nm

The turbopump with ConFlat inlet flange must be fixed to the vacuum chamber by means of the appropriate Varian hardware. See the appendix "Technical Information" for a detailed description.

When the pump rest on its legs, attach them to the bench using the M6 threaded holes in the legs where the rubber feet are installed. These holes are located on a 285 mm (11.22 inches) diameter.

For installation of optional accessories, see "Technical Information".

USE

All the instructions for the correct use of the turbopump are contained in the control unit manual.

Read the manual carefully before using the pump.

In order to achieve a better (lower) base pressure, the pump casing may be heated using the optional heater. While heating the pump, the temperature of its inlet flange must not exceed 120 °C. Always use the water cooling system during the heating operations (see annex "Technical information" for details about the water cooling connection).



WARNING!

Do not touch the turbopump or any of its accessories during the heating process. The high temperatures may cause burns.



CAUTION

Use air or inert gas free from dust or particles for venting the pump. The pressure at the vent port must be less than 2 bar (above atmospheric pressure).



CAUTION

Avoid impacts or harsh movements of the pump when in operation. The bearings may become damaged.



CAUTION

For pumping aggressive gases, these pumps are fitted with a special port to allow a steady flow of inert gas (like N₂, Ar) for pump bearing protection (see the appendix "Technical Information").



WARNING!

When employing the pump for pumping toxic, flammable, or radioactive gases, please follow the required procedures for each gas disposal.

Do not use the pump in presence of explosive gases.

MAINTENANCE

The Turbo-V 1800A series pump does not require any maintenance. Any work performed on the pump must be carried out by authorized personnel.



WARNING!

Before carrying out any work on the turbopump, disconnect it from the supply, vent the pump by opening the appropriate valve, wait until the rotor has stopped turning and wait until the surface temperature of the pump falls below 50 °C.

In the case of breakdown, contact your local Varian service center who can supply a reconditioned pump to replace that broken down.

NOTE

Before returning the pump to the constructor for repairs, or replacement with a reconditioned unit, the "Health and Safety" sheet attached to this instruction manual must be filled-in and sent to the local sales office. A copy of the sheet must be inserted in the pump package before shipping.

If a pump is to be scrapped, it must be disposed of in accordance with the specific national standards.

DESCRIPTION OF THE TURBOPUMP

The Turbo-V1800A pump is available in three models. The three models, which differ only in the high vacuum flange, are:

- Model 969-9064 with ISO 250 high vacuum flange
- Model 969-9065 with ConFlat 12" external diameter high vacuum flange
- Model 969-9066 with ConFlat 12.5" external diameter high vacuum flange

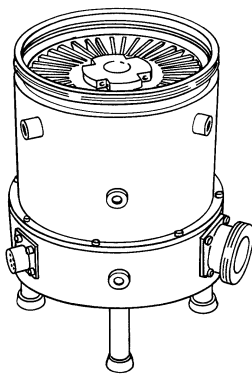

Model 969-9064

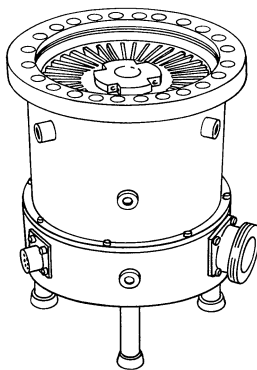

Model 969-9065

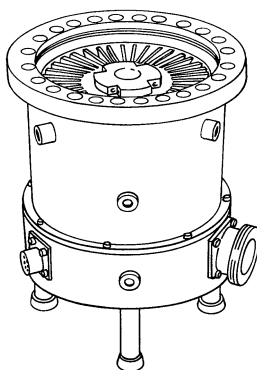

Model 969-9066

The Turbo-V1800A pump consists of a medium frequency motor driving a turbine fitted with 12 bladed stages. The turbine rotates in an anticlockwise direction when viewed from the high vacuum flange end.

The turbine is made of high-strength, light aluminium alloy, and is machined from a single block of aluminium. The first 3 high vacuum stages have blade angles of 40°, the subsequent four stages have blade angles of 30°, and the lower stages have blade angles of 20°.

The turbine rotor is supported by high precision ceramic ball bearings lubricated with a proprietary process located on the forevacuum side of the pump.

The static blades of the stator are made of stainless steel. These are supported and accurately positioned by spacer rings.

During normal operation, the motor is fed with a voltage of 90 Vac three-phase at 450 Hz. To reduce losses during start-up to a minimum, the frequency increases according to a ramp with a higher initial voltage/frequency ratio.

A water jacket surrounds the pump stator and is used to cool the motor, which operates in the forevacuum region of the pump. Cooling water is connected to the pump via two ruffled nozzles on the cooling jacket.

A thermistor sensor is mounted directly on the motor stator and pump body to prevent the pump from overheating. The thermistor sensor, the motor stator windings and the earth are connected to a Turbo-V controller through a 7 pin socket on the side of the pump.

The pump is balanced after assembly with a residual vibration amplitude less than 0.02 µm.

The pump must be mounted vertically or upside down, with a maximum allowable slope of 10°. It can be suspended by inlet flange or rest upon its support legs. The connection of the forevacuum on the side of the pump is an ISO 63 flange.

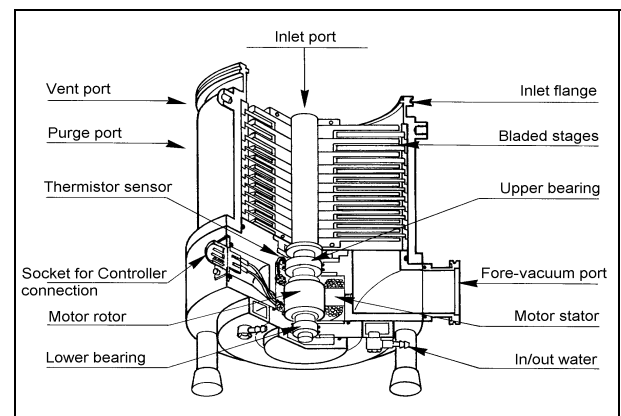

TECHNICAL SPECIFICATION

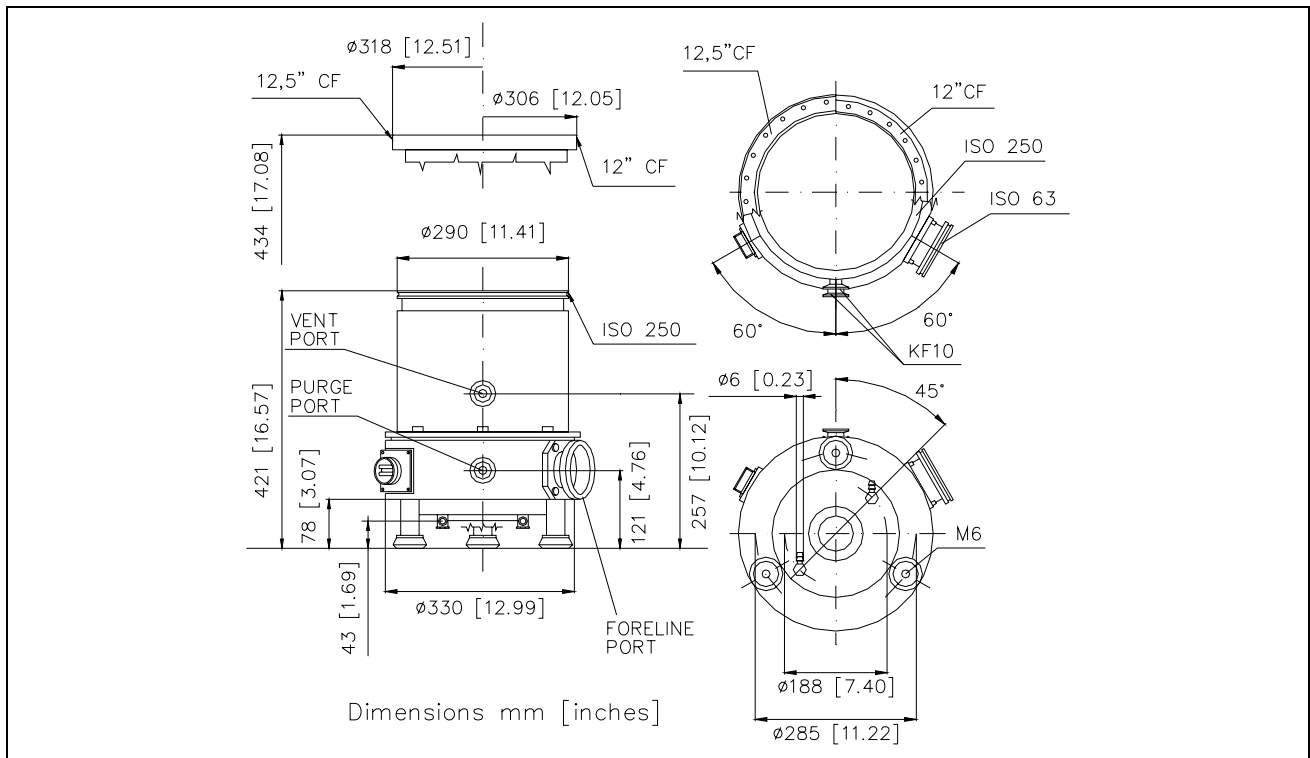

Pumping speed	N ₂ : 1600 l/s He: 1850 l/s H ₂ : 1750 l/s
Compression ratio	N ₂ : >1 x 10 ¹⁰ He: 2.5 x 10 ⁵ H ₂ : 6 x 10 ³
Base pressure*	1 x 10 ⁻¹⁰ mbar (7.5 x 10 ⁻¹¹ Torr)
Inlet flange	ISO 250 CFF 12" CFF 12.5"
Foreline flange	ISO 63
Vent port flange	KF 10 NW
Purge port flange	KF 10 NW
Rotational speed	27000 rpm
Start-up time	10 minutes
Recommended forepump	Varian SD 700
Operating position	Vertical/inverted (max slope 10°)
Operating ambient temperature	+ 5° C to + 35° C

Coolant water	flow: 70 l/h (0.3 GPM) temperature: +10° C to +30° C pressure: 2 to 4 bar (30 to 60 Psi)
Bakeout temperature	120° C at inlet flange maximum
Vibration level (displacement)	< 0.02 μm at inlet flange
Noise level	≤ 52 dB (A) at 1 meter
Input	90 Vac, three phase, 450 Hz
Lubricant	permanent lubrication
Storage temperature	- 20° C to + 70° C
Weight kg (lbs)	62 (137)

* According to standard DIN 28 428, the base pressure is that measured in a leak-free test dome, 48 hours after the completion of test dome bake-out, with a Turbopump fitted with a ConFlat flange and using the recommended pre-vacuum pump.

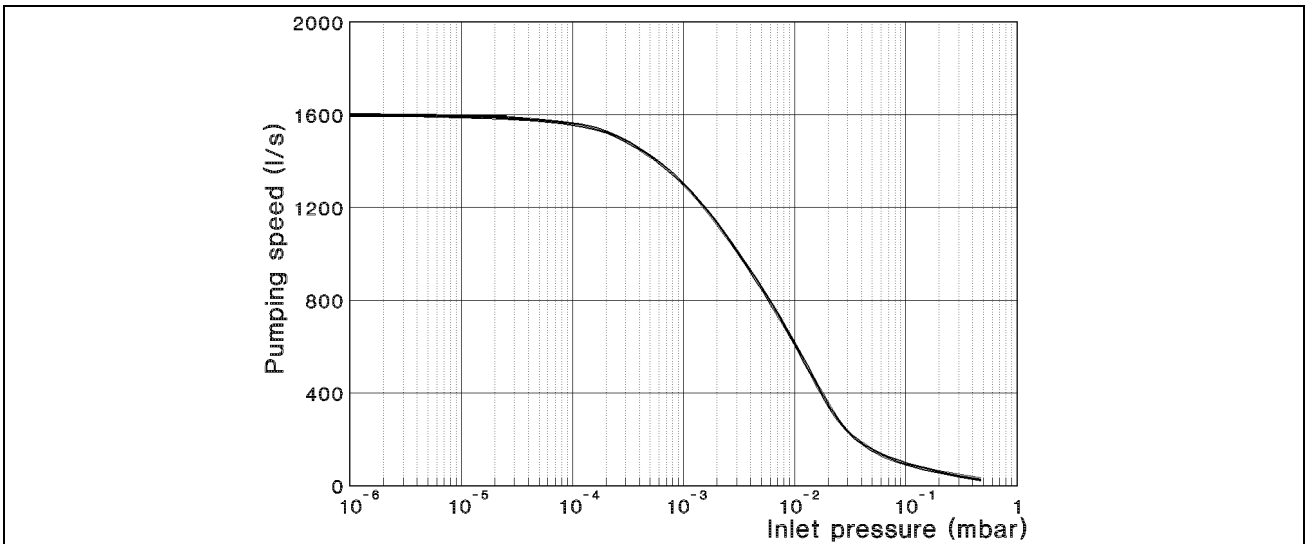

Graph of nitrogen pumping speed vs inlet pressure

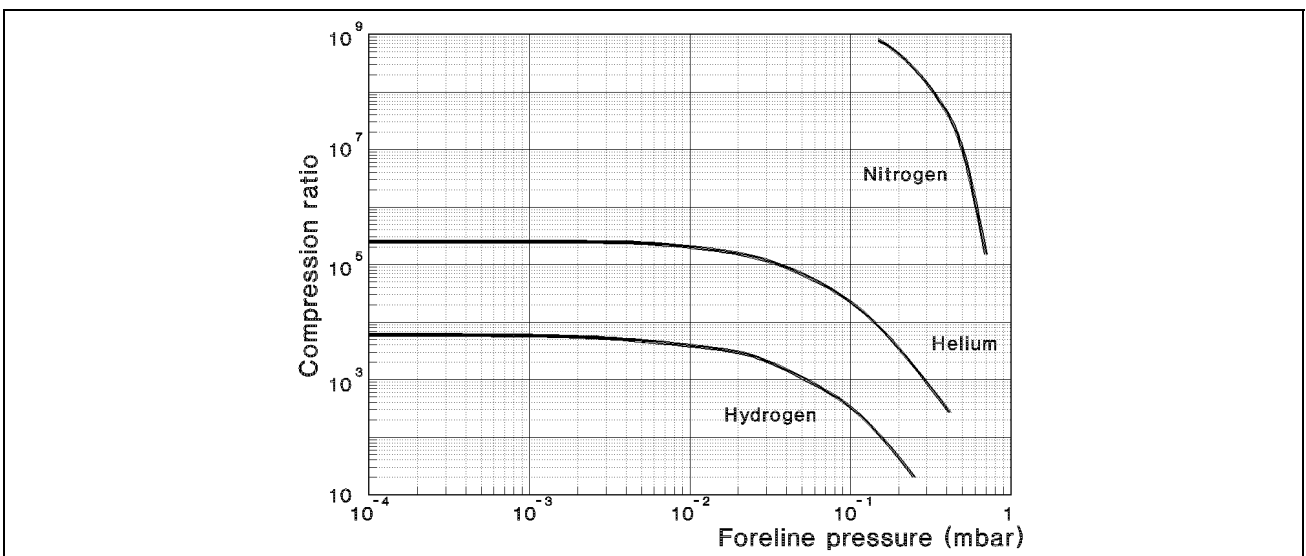

Graph of compression ratio vs foreline pressure

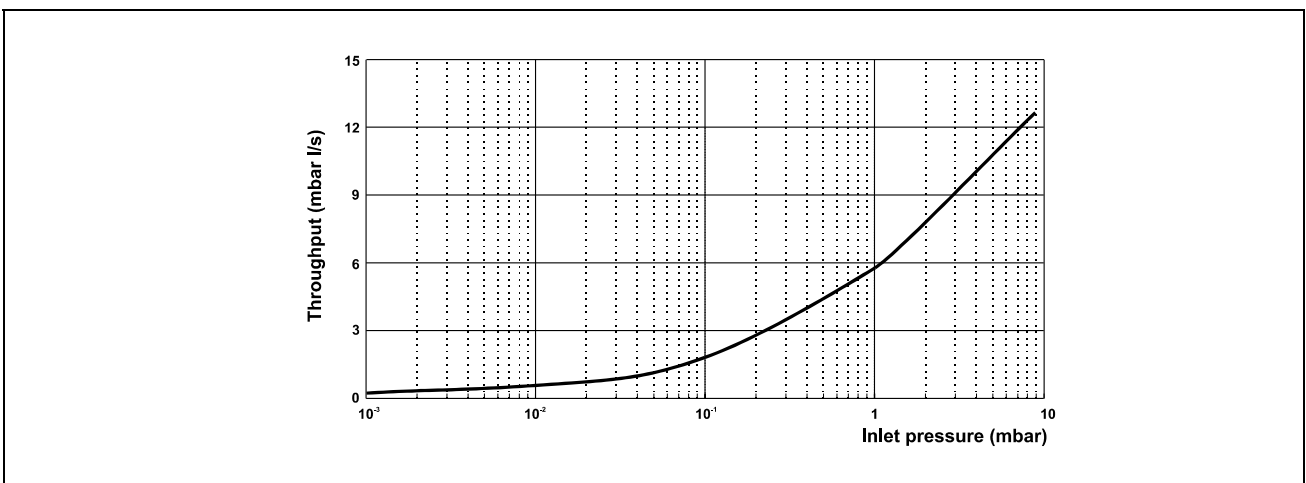

Graph of nitrogen throughput vs inlet pressure using the recommended mechanical forevacuum pump

INLET SCREEN INSTALLATION

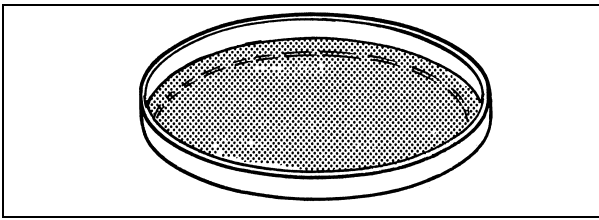

The inlet screens mod. 969-9306 prevents the blades of the pump from being damaged by debris greater than 2 mm diameter.

The inlet screen, however, will reduce the pumping speed by about 15%.

The inlet screen is fitted in the upper part of the pump, as shown in the figure.

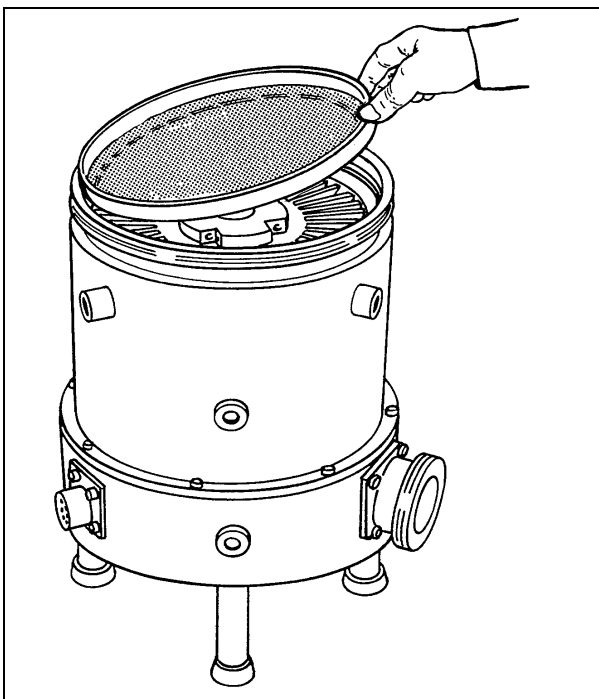

The screen can be mounted on each pump model.

The following figure show the overall flange dimensions with the protection screen fitted on pump with ISO flange and pump with CFF flange.

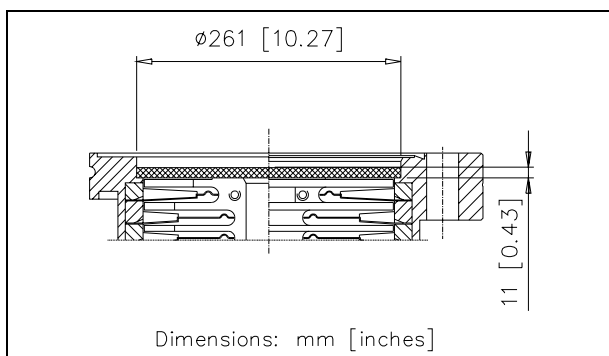

HEATER BAND INSTALLATION

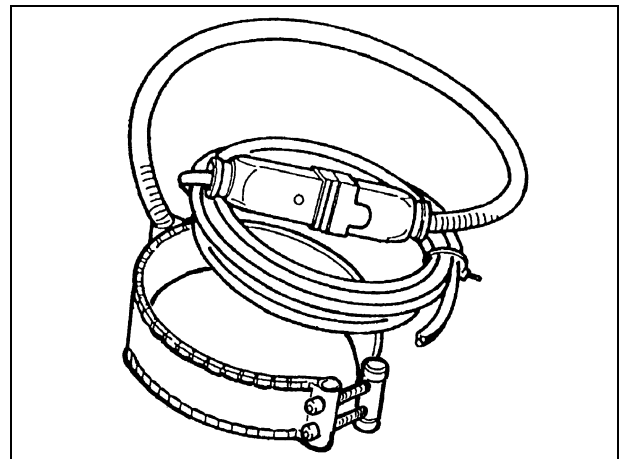

The heater band model 969-9811 and 969-9812 can be used to heat the pump casing when a bakeout is needed.

The heater band is applied to the upper part of the pump casing, as shown in the figure, and heats it to a temperature of about 80° C.

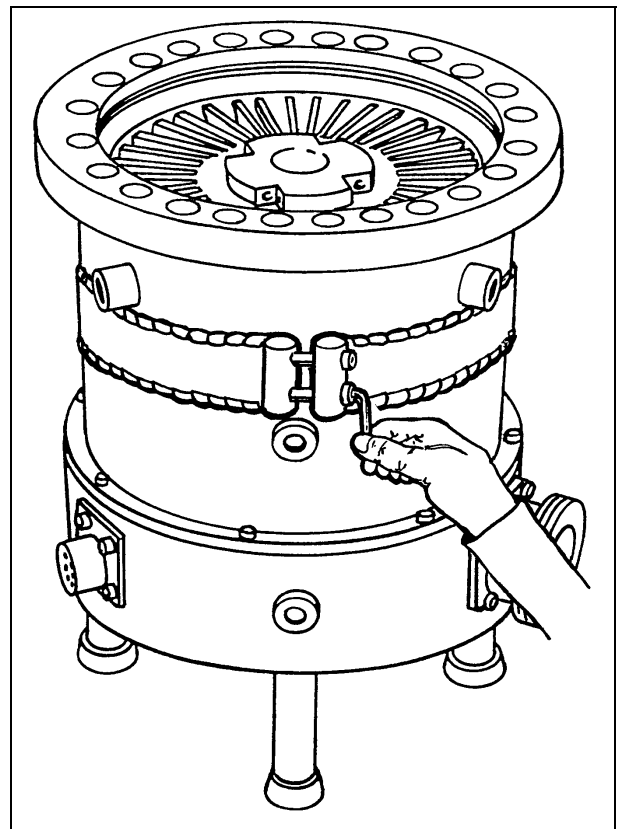

The heater band must be mounted such that there is perfect thermal contact with the pump wall to obtain fast and efficient heating.

Switch on the heater while the turbopump is in operation. In the event of turbopump overheat, the heater will be automatically cut out by the thermistor sensor.

NOTE

The turbopump must be "baked" only when operating with an inlet pressure less than 10^{-4} mbar and with water cooling.

CAUTION

If the chamber of the system is "baked" at a high temperature, a shield should be installed to prevent thermal radiation heating the high vacuum flange on the pump. The maximum temperature allowed for the inlet flange is 120° C.

GAS PURGE VALVE INSTALLATION

A gas purge valve is available to protect the pump bearings against particulate and corrosive gases that could move into the pump.

To install the gas purge valve it is necessary to lock the purge valve in position using the KF klamp as shown in the following figure.

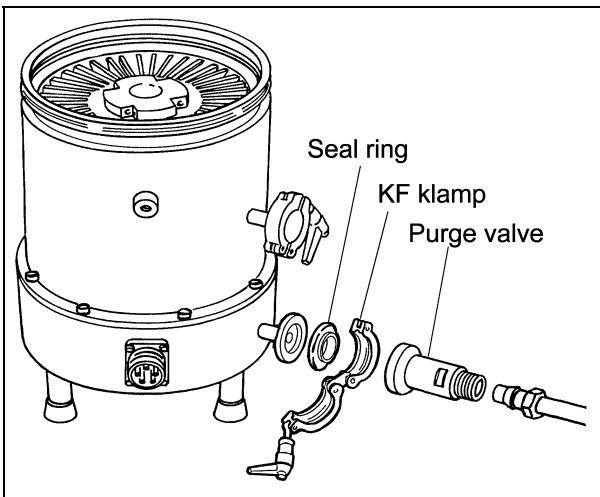

VENT VALVE INSTALLATION

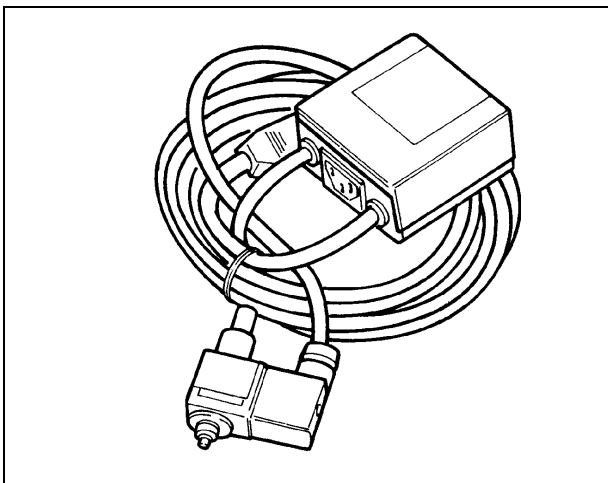

The vent valve mod. 969-9833 allows to avoid undesired venting of the pump during a temporary

power failure (5 sec maximum), and enables an automatic vent operation.

Screw the vent valve into the vent port of the pump and tighten it using a 10 mm. hexagonal spanner with a torque of 2.5 Nm.

CAUTION

Do not overtighten the valve as this may damage the thread on the pump.

VENT DEVICE INSTALLATION

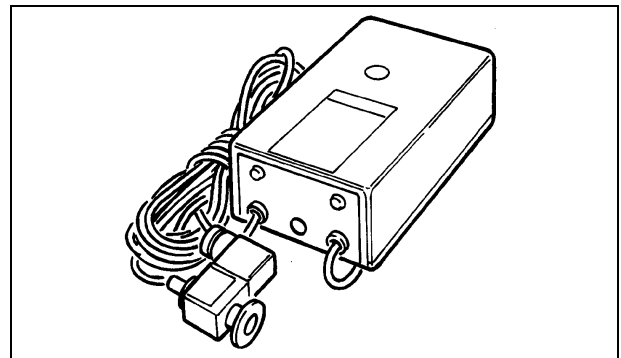

The vent device mod. 969-9831 allows to avoid undesired venting of the pump during a temporary power failure (adjustable time up to 36 min.), and enables an automatic vent operation.

Assemble the seal ring and lock the vent device in position using the KF klamp as shown in the following figure.

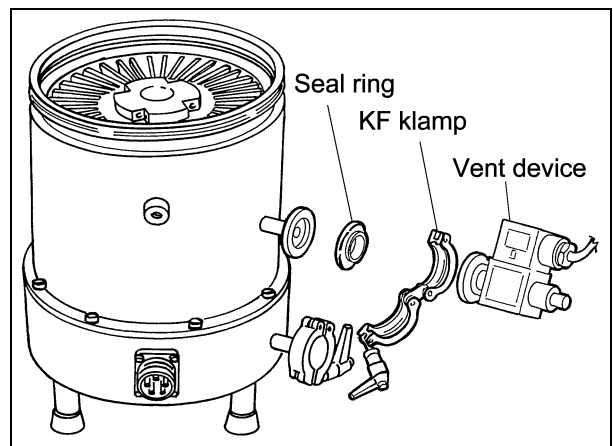

TYPICAL LAYOUT DIAGRAM

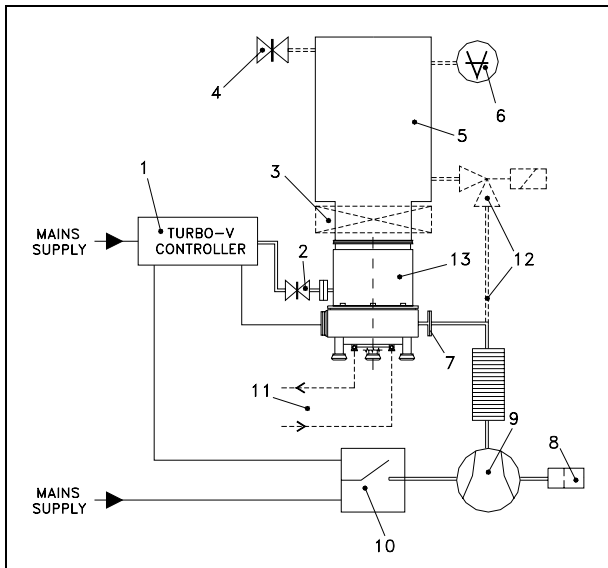

1. Turbo-V controller
2. Vent valve
3. Vacuum pump shut-off valve (optional)
4. System vent valve (optional)
5. Vacuum chamber
6. Ionisation gauge
7. Fore-vacuum pump connecting flange
8. Oil mist eliminator
9. Fore-vacuum pump with internal one-way valve
10. Fore-vacuum pump control relay
11. Connection for water cooling
12. Roughing line with valve (optional)
13. Turbopump
14. Flexible connection

Connection A - HIGH VACUUM FLANGE

To connect the Turbo pump to the ISO inlet flange, remove the outer ring and position the centering ring as shown in the figure.

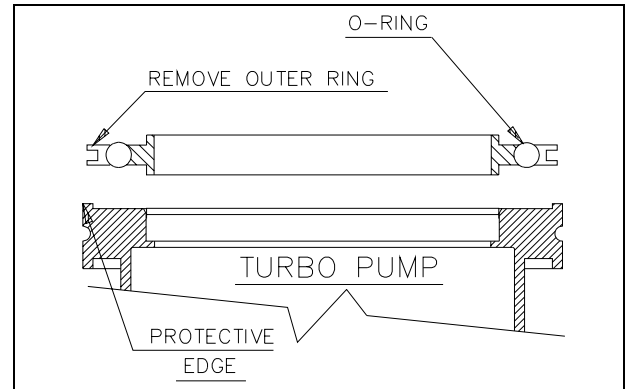

Then fix the two flanges with the clamps or claws as shown in the figure.

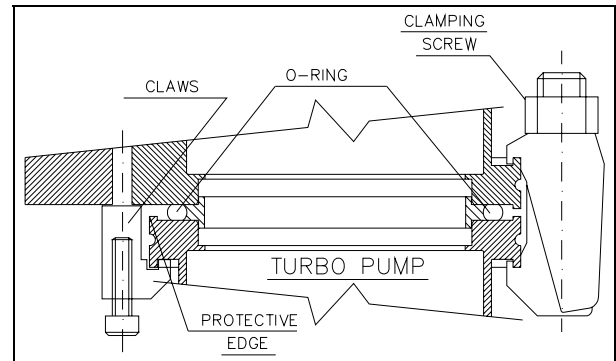

For ConFlat flange connections we recommend using Varian hardware.

To facilitate assembly and dismantling, apply Felpro C-100 high temperature lubricant to the screw threads protruding from the flange and between the nuts and flange.

Attach the units and tighten each one in turn. Repeat the sequential tightening until the flange faces meet.

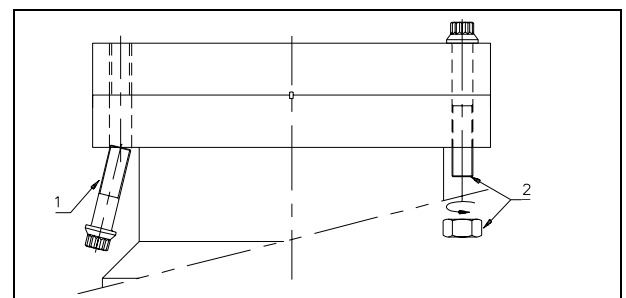

CAUTION

Exercise care when tightening nuts and bolts to avoid creating dents in the envelope as this may cause the pump rotor to lock.

Connection B - FORE-VACUUM PUMP

A flange ISO 63 is available to connect the Turbopump to the fore-vacuum pump. A hose or vacuum approved pipe can be used. If a rigid pipe is used, any vibration generated by the mechanical pump must be eliminated through the use of bellows.

NOTE

The Turbo pump is characterised by its high compression ratio also for oil vapours. When using a mechanical oil-sealed pump, it is advisable to install a suitable trap between the turbopump and the fore-vacuum pump in order to prevent oil back-streaming.

Connection C - ELECTRICAL

The turbopump is connected to the controller through an 7-pin connector. Pins B, G and E are the 3-phase supply to the motor, pins A and F are connected to the temperature sensor (NTC type, 30 KΩ resistance at 20° C) and pins C and D are available for further connections.

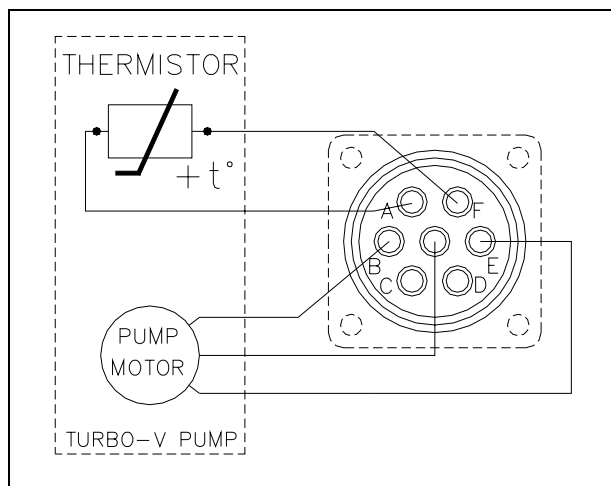

The ground cable should be connected to the controller. If the temperature sensor is disconnected, the pump will not start. To prevent damage to the pump when the temperature exceeds 60° C, the sensor automatically cuts out the power supply.

WATER COOLING CONNECTION

The turbopump must be used with the water cooling connected. To connect the water cooling to the turbopump see the following figure.

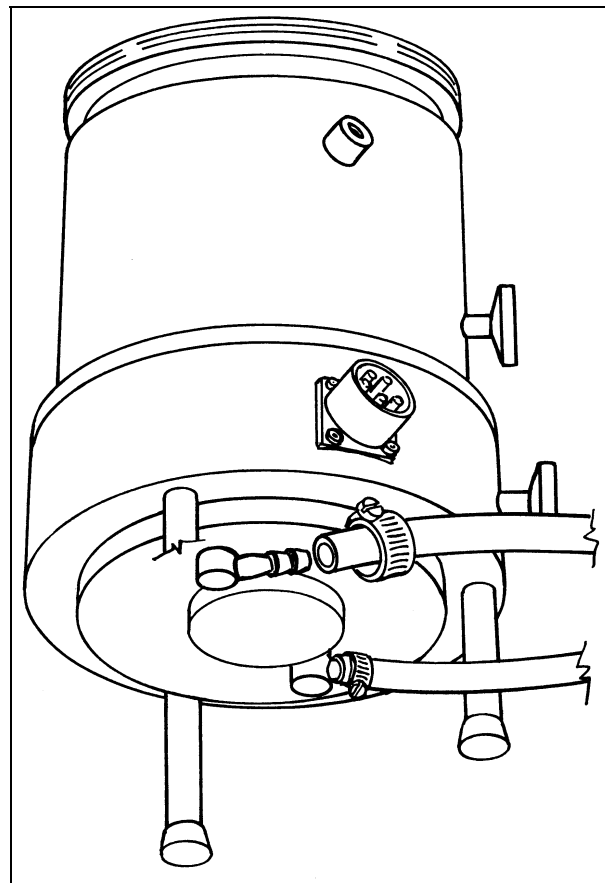

PUMP USED WITH CORROSIVE GASES

To prevent damage to the bearings, an inert gas must flow into the pump body around the upper bearing towards the forevacuum line. To supply the inert purge gas (e. g. nitrogen, argon) to the pump through the purge port, connect a gas purge valve between the pressure regulator and the pump (see the following figure). Adjust the pressure regulator in order to read a gas flow rate of 0.1 to 0.8 mbar l/s.

CAUTION

To prevent bearing damage, Varian suggests a minimum purge gas flow rate of 10 sccm (0.17 mbar l/s). This value can be exceeded, according to the process requirements. Please contact Varian for specific applications.

The purge gas throughput with the recommended forepump of 15 m³ /h (11 CFM) allows to achieve a high vacuum pressure in the 10⁻⁸ mbar range.

The recommended gas flow maintains a pressure into the pump body higher than the forevacuum pressure.

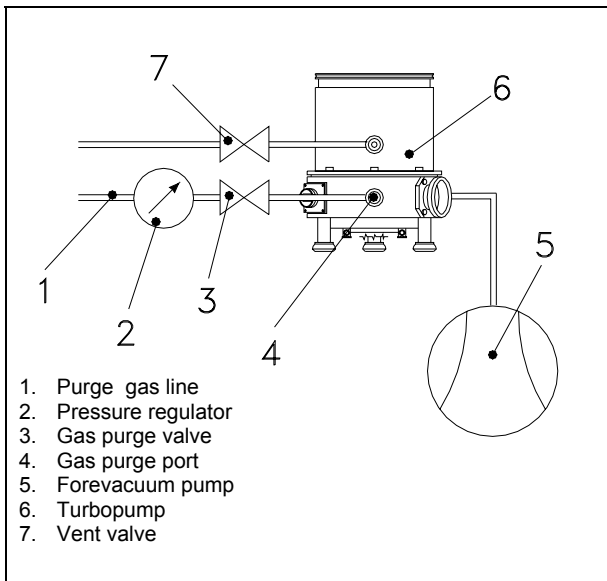

The recommended procedure to vent the system and the pump avoiding the contact between the pump bearings and the corrosive gas is described in the following points:

1. Close the corrosive gas flow into the system.
2. Leaving the Turbo-V pump and the backing pump running and the purge gas flowing, wait for enough time to evacuate the corrosive gas from the system.
3. Open the Turbo-V vent port slowly until to reach atmospheric pressure in the system.
4. Turn off the Turbopump.
5. When the Turbo-V pump and the backing pump are stopped and the system is at atmospheric pressure, for a better bearing protection it is advisable to leave the purge gas flowing into the Turbo-V pump, with the chamber or the Turbo-V vent valve opened, to avoid system overpressures. If the vent valve can't be kept opened, the backing pump should be left operating.

PUMP USED IN PRESENCE OF MAGNETIC FIELDS

Magnetic fields induce eddy currents in the rotor of a turbomolecular pump that tend to oppose to its rotation.

The result is increased electrical power consumption by the motor, most of which is dissipated in the rotor.

Since the rotor is not in contact with the stator the above power can leave the rotor mainly by radiation and hence the rotor may be overheated while static parts of the pump remain cool.

This effect is strongly dependant from the intensity, time function and distribution of the magnetic field.

In general, therefore, an increase in pump current can be expected.

If this increase is lower than 50% of the current value drawn by the motor in high vacuum operation, no particular problem should be expected.

However if the effect is grater, than the case should be carefully reviewed by Varian's specialist. As a matter of fact, in case of high magnetic fields, also important forces might be generated and applied to the rotor.

ACCESSORIES

DESCRIPTION	PART NUMBER
Inlet screen, ISO 250	969-9306
Heater band, 120 V	969-9812
Heater band, 220 V	969-9811
Vent valve with fixed delay time	969-9833
Vent device with adjustable delay time	969-9831
Forepump SD 700, with 3 ph., 220/380 V, 50 Hz motor	949-0860-080
Forepump SD 700 with 1 ph., 120/220 V, 60 Hz motor	0424-P1241-307
Forepump SD 700, with 3 ph., universal motor	0424-P1241-337

For a complete overview of Varian's extensive product lines, please refer to the Varian catalog.



Request for Return



1. A Return Authorization Number (RA#) **WILL NOT** be issued until this Request for Return is completely filled out, signed and returned to Varian Customer Service.
2. Return shipments shall be made in compliance with local and international **Shipping Regulations** (IATA, DOT, UN).
3. The customer is expected to take the following actions to ensure the **Safety** of workers at Varian: (a) Drain any oils or other liquids, (b) Purge or flush all gasses, (c) Wipe off any excess residues in or on the equipment, (d) Package the equipment to prevent shipping damage, (for Advance Exchanges please use packing material from replacement unit).
4. Make sure the shipping documents clearly show the RA# and then return the package to the Varian location nearest you.

North and South America

Varian Vacuum Technologies
 121 Hartwell Ave
 Lexington, MA 02421
 Phone : +1 781 8617200
 Fax: +1 781 8609252

Europe and Middle East

Varian SpA
 Via Flli Varian 54
 10040 Leini (TO) – ITALY
 Phone: +39 011 9979111
 Fax: +39 011 9979330

Asia and ROW

Varian Vacuum Technologies
 Local Office

CUSTOMER INFORMATION

Company name:	
Contact person: Name:	Tel:
Fax:	E-Mail:
Ship Method:	Shipping Collect #: P.O.#:
<i>Europe only:</i> VAT reg. Number:	<i>USA only:</i> <input type="checkbox"/> Taxable <input type="checkbox"/> Non-taxable
Customer Ship To:	Customer Bill To:
.....
.....

PRODUCT IDENTIFICATION

Product Description	Varian P/N	Varian S/N	Purchase Reference

TYPE OF RETURN (check appropriate box)

<input type="checkbox"/> Paid Exchange	<input type="checkbox"/> Paid Repair	<input type="checkbox"/> Warranty Exchange	<input type="checkbox"/> Warranty Repair	<input type="checkbox"/> Loaner Return
<input type="checkbox"/> Credit	<input type="checkbox"/> Shipping Error	<input type="checkbox"/> Evaluation Return	<input type="checkbox"/> Calibration	<input type="checkbox"/> Other

HEALTH and SAFETY CERTIFICATION

Varian Vacuum Technologies **CAN NOT ACCEPT** any equipment which contains **BIOLOGICAL HAZARDS** or **RADIOACTIVITY**. Call Varian Customer Service to discuss alternatives if this requirement presents a problem.

The equipment listed above (check one):

HAS NOT been exposed to any toxic or hazardous materials

OR

HAS been exposed to any toxic or hazardous materials. In case of this selection, check boxes for any materials that equipment was exposed to, check all categories that apply:

- Toxic Corrosive Reactive Flammable Explosive Biological Radioactive

List all toxic or hazardous materials. Include product name, chemical name and chemical symbol or formula.

.....

Print Name: Customer Authorized Signature:

Print Title: Date:/...../.....

NOTE: If a product is received at Varian which is contaminated with a toxic or hazardous material that was not disclosed, **the customer will be held responsible** for all costs incurred to ensure the safe handling of the product, and **is liable** for any harm or injury to Varian employees as well as to any third party occurring as a result of exposure to toxic or hazardous materials present in the product.

Do not write below this line

Notification (RA)#: Customer ID#: Equipment #:

FAILURE REPORT

TURBO PUMPS and TURBOCONTROLLERS

<input type="checkbox"/> Does not start <input type="checkbox"/> Does not spin freely <input type="checkbox"/> Does not reach full speed <input type="checkbox"/> Mechanical Contact <input type="checkbox"/> Cooling defective	<input type="checkbox"/> Noise <input type="checkbox"/> Vibrations <input type="checkbox"/> Leak <input type="checkbox"/> Overtemperature	POSITION <input type="checkbox"/> Vertical <input type="checkbox"/> Horizontal <input type="checkbox"/> Upside-down <input type="checkbox"/> Other:	PARAMETERS Power: Rotational Speed: Current: Inlet Pressure: Temp 1: Foreline Pressure: Temp 2: Purge flow: <hr/> OPERATION TIME:
TURBOCONTROLLER ERROR MESSAGE:			

ION PUMPS/CONTROLLERS

<input type="checkbox"/> Bad feedthrough <input type="checkbox"/> Vacuum leak <input type="checkbox"/> Error code on display	<input type="checkbox"/> Poor vacuum <input type="checkbox"/> High voltage problem <input type="checkbox"/> Other
Customer application:	

VALVES/COMPONENTS

<input type="checkbox"/> Main seal leak <input type="checkbox"/> Solenoid failure <input type="checkbox"/> Damaged sealing area	<input type="checkbox"/> Bellows leak <input type="checkbox"/> Damaged flange <input type="checkbox"/> Other
Customer application:	

LEAK DETECTORS

<input type="checkbox"/> Cannot calibrate <input type="checkbox"/> Vacuum system unstable <input type="checkbox"/> Failed to start	<input type="checkbox"/> No zero/high background <input type="checkbox"/> Cannot reach test mode <input type="checkbox"/> Other
Customer application:	

INSTRUMENTS

<input type="checkbox"/> Gauge tube not working <input type="checkbox"/> Communication failure <input type="checkbox"/> Error code on display	<input type="checkbox"/> Display problem <input type="checkbox"/> Degas not working <input type="checkbox"/> Other
Customer application:	

PRIMARY PUMPS

<input type="checkbox"/> Pump doesn't start <input type="checkbox"/> Doesn't reach vacuum <input type="checkbox"/> Pump seized	<input type="checkbox"/> Noisy pump (describe) <input type="checkbox"/> Over temperature <input type="checkbox"/> Other
Customer application:	

DIFFUSION PUMPS

<input type="checkbox"/> Heater failure <input type="checkbox"/> Doesn't reach vacuum <input type="checkbox"/> Vacuum leak	<input type="checkbox"/> Electrical problem <input type="checkbox"/> Cooling coil damage <input type="checkbox"/> Other
Customer application:	

FAILURE DESCRIPTION

(Please describe in detail the nature of the malfunction to assist us in performing failure analysis):

NOTA: Su richiesta questo documento è disponibile anche in Tedesco, Italiano e Francese.
REMARQUE : Sur demande ce document est également disponible en allemand, italien et français.
HINWEIS: Auf Anfrage ist diese Unterlage auch auf Deutsch, Italienisch und Französisch erhältlich.

Sales and Service Offices

Argentina **Varian Argentina Ltd.**

Sucursal Argentina
Av. Ricardo Balbin 2316
1428 Buenos Aires
Argentina
Tel: (54) 1 783 5306
Fax: (54) 1 786 5172

Australia **Varian Australia Pty Ltd.**

679-701 Springvale Road
Mulgrave, Victoria ZZ 3170
Australia
Tel: (61) 395607133
Fax: (61) 395607950

Benelux **Varian Vacuum Technologies**

Rijksstraatweg 269 H,
3956 CP Leersum
The Netherlands
Tel: (31) 343 469910
Fax: (31) 343 469961

Brazil **Varian Industria e Comercio Ltda.**

Avenida Dr. Cardoso de Mello 1644
Vila Olimpia
Sao Paulo 04548 005
Brazil
Tel: (55) 11 3845 0444
Fax: (55) 11 3845 9350

Canada **Central coordination through:**

Varian Vacuum Technologies
121 Hartwell Avenue
Lexington, MA 02421
USA
Tel: (781) 861 7200
Fax: (781) 860 5437
Toll Free: (800) 882 7426

China **Varian Technologies - Beijing**

Room 1201, Jinyu Mansion
No. 129A, Xuanwumen Xidajie
Xicheng District
Beijing 1000031 P.R. China
Tel: (86) 10 6608 1530
Fax: (86) 10 6608 1534

France and Wallonie **Varian s.a.**

7 avenue des Tropiques
Z.A. de Courtaboeuf – B.P. 12
Les Ulis cedex (Orsay) 91941
France
Tel: (33) 1 69 86 38 13
Fax: (33) 1 69 28 23 08

Germany and Austria **Varian Deutschland GmbH**

Alsfelder Strasse 6
Postfach 11 14 35
64289 Darmstadt
Germany
Tel: (49) 6151 703 353
Fax: (49) 6151 703 302

India **Varian India PVT LTD**

101-108, 1st Floor
1010 Competent House
7, Nangal Raya Business Centre
New Delhi 110 046
India
Tel: (91) 11 5548444
Fax: (91) 11 5548445

Italy **Varian Vacuum Technologies**

Via F.lli Varian, 54
10040 Leini, (Torino)
Italy
Tel: (39) 011 997 9111
Fax: (39) 011 997 9350

Japan **Varian Vacuum Technologies**

Sumitomo Shibaura Building, 8th Floor
4-16-36 Shibaura
Minato-ku, Tokyo 108
Japan
Tel: (81) 3 5232 1253
Fax: (81) 3 5232 1263

Korea **Varian Technologies Korea, Ltd.**

Shinsa 2nd Bldg. 2F
966-5 Daechi-dong
Kangnam-gu, Seoul
Korea 135-280
Tel: (82) 2 3452 2452
Fax: (82) 2 3452 2451

Mexico **Varian S.A.**

Concepcion Beistegui No 109
Col Del Valle
C.P. 03100
Mexico, D.F.
Tel: (52) 5 523 9465
Fax: (52) 5 523 9472

Taiwan **Varian Technologies Asia Ltd.**

18F-13 No.79, Hsin Tai Wu Road
Sec. 1, Hsi Chih
Taipei Hsien
Taiwan, R.O.C.
Tel: (886) 2 2698 9555
Fax: (886) 2 2698 9678

UK and Ireland **Varian Ltd.**

28 Manor Road
Walton-On-Thames
Surrey KT 12 2QF
England
Tel: (44) 1932 89 8000
Fax: (44) 1932 22 8769

United States **Varian Vacuum Technologies**

121 Hartwell Avenue
Lexington, MA 02421
USA
Tel: (781) 861 7200
Fax: (781) 860 5437
Toll Free: (800) 882 7426

Other Countries **Varian Vacuum Technologies**

Via F.lli Varian, 54
10040 Leini, (Torino)
Italy
Tel: (39) 011 997 9111
Fax: (39) 011 997 9350

Internet Users:

Customer Service & Technical Support:
vtt.customer.service@varianinc.com

Worldwide Web Site:
www.varianinc.com/vacuum

Order On-line:
www.evarian.com

Representatives in most countries



VARIAN